

The Cohomology Groups of Stable Quasi-abelian Schemes and Degenerations Associated with the E_8 -lattice

Iku Nakamura¹ and Ken Sugawara

Abstract.

We study certain degenerate abelian schemes (Q_0, L_0) that are GIT-stable in the sense that their SL-orbits are closed in the semistable locus. We prove the vanishing of the cohomology groups $H^q(Q_0, L_0^n) = 0$ for $q, n > 0$ for a naturally defined ample invertible sheaf L_0 on Q_0 . When $n = 1$, this implies that $H^0(Q_0, L_0)$, the space of global sections, is an irreducible module of the noncommutative Heisenberg group of (Q_0, L_0) .

§1. Introduction

In 1970's Namikawa [Nw76] and Nakamura [Nr75] studied the problem of compactifying the moduli A_g of abelian varieties over \mathbf{C} , and their papers introduced a certain class of degenerate abelian varieties. In 1990's in their joint work [AN99] Alexeev and Nakamura again discussed the same problem of compactifying A_g over any field in an algebraic manner, and the objects they studied are nearly the same as those studied by Namikawa and Nakamura in 1970's.

After their joint work [AN99] Alexeev and Nakamura independently constructed respectively reasonable compactifications, using almost the same class of degenerate abelian varieties or schemes as above. Alexeev's moduli \overline{A}_g [A02] is a coarse moduli of a certain kind of principally polarized reduced, possibly degenerate, abelian varieties with (continuous) group action. On the other hand Nakamura's moduli [Nr99] is a fine moduli $SQ_{g,K}$ of polarized, possibly nonreduced, possibly degenerate, abelian schemes which are GIT-stable in the sense that their

Received April 11, 2005.

Revised April 24, 2006.

¹ Partially supported by JSPS, Grant in Aid for Scientific Research (A) 16204001.

SL-orbits are closed in the semistable locus, though their stabilizer subgroups of SL could be of infinite order. The moduli $SQ_{g,K}$ compactifies the moduli scheme $A_{g,K}$ of abelian varieties with certain *noncommutative* level K -structures (to be more precise, of abelian varieties, each with a very ample invertible sheaf linearized with regards to the Heisenberg group $G(K)$) where K is a certain symplectic, sufficiently large finite abelian group. We note that both \overline{A}_g and $SQ_{g,K}$ are projective over \mathbf{Z} or $\mathbf{Z}[\zeta_N, \frac{1}{N}]$ respectively where $N = \sqrt{|K|}$. Since $SQ_{g,K}$ is a fine moduli, there is a universal family over $SQ_{g,K}$ of polarized *generalized* abelian schemes of dimension g so that any fibre of the family over a geometric point of $SQ_{g,K}$ represents an isomorphism class corresponding to the geometric point. We call any fibre of the family a *projectively stable quasi-abelian scheme*, or simply a PSQAS. We note that a PSQAS is singular if and only if the PSQAS lies over the boundary $SQ_{g,K} \setminus A_{g,K}$.

The purpose of this article is first of all to prove the vanishing of certain cohomology groups of PSQASes. This solves a conjecture raised by [Nr99, section 9] in the affirmative. The second purpose of this article is to study PSQASes associated with the E_8 lattice. The structures of some of PSQASes over the boundary of $SQ_{g,K}$ are very complicated when they are nonreduced. Any even unimodular definite lattice provides us with a nonreduced PSQAS. Since there are at least $8 \cdot 10^7$ inequivalent even unimodular definite lattice for $g = 32$, there could be a lot of nonreduced PSQASes. The first nontrivial example of a nonreduced PSQAS is provided by E_8 [AN99], which we will study in detail in the second half of the article. As a matter of fact, this detailed study of the E_8 -case removes the last psychological obstacle for our complete computation of the cohomology groups of PSQASes in the general case.

The article is organized as follows. The first two sections 2 and 3 recall the basic facts about Delaunay decompositions and degenerating families of abelian varieties. We construct a particular class of degenerating families (Q, L) of polarized abelian varieties over complete discrete valuation rings, whose closed fibres (Q_0, L_0) are nothing but the PSQASes mentioned above. The sections 4, 5 and 6 are devoted to studying closed fibres (Q_0, L_0) of the families (Q, L) , in particular, their cohomology groups $H^q(Q_0, L_0^n)$ in the general case including the case where Q_0 is nonreduced. In the section 5, the following Theorem 1 is proved, while in the section 4 an outline of the proof is explained. A key result for proving Theorem 1 is proved in the section 6.

Theorem 1. *Let (Q_0, L_0) be a PSQAS. Then $H^q(Q_0, L_0^n) = 0$ for $q > 0$ and $n > 0$.*

An important corollary to it is the following

Theorem 2. *Let K be a finite symplectic abelian group of order N^2 . Let k be any field over $\mathbf{Z}[\zeta_N, \frac{1}{N}]$. Let $G(K)$ be a noncommutative finite Heisenberg group, namely a central extension of K by the group μ_N of N -th roots of unity. Let (Q_0, L_0) be a PSQAS over k with a level $G(K)$ -structure in the sense of [Nr99]. Then $H^0(Q_0, L_0)$ is an irreducible $G(K)$ -module of weight one.*

Let L be the natural polarization of the universal family of PSQASes over $SQ_{g,K}$. By Theorem 1 the 0-th direct images of L^n ($n \geq 1$) are locally free sheaves over $SQ_{g,K}$, whose determinant bundles are expected to give rise to the most natural ample invertible sheaves of $SQ_{g,K}$.

The second half of the article starting from the section 7 is devoted to studying a PSQAS Q_0 associated with E_8 . Among other things the nilradical of O_{0,Q_0} is calculated completely in the section 11. This calculation helps us to get convinced that nilpotent elements of O_{0,Q_0} have large support and that therefore the cohomology groups $H^q(Q_0, L_0^n)$ will behave in the same manner as those of nonsingular abelian varieties. This was psychologically a key step to the proof of Theorem 1.

We would like to thank Professor K. Shinoda for his many advices on E_8 during the preparation of the article.

§2. Basic facts about Delaunay decompositions

Let \mathbf{Z} be the set of integers, \mathbf{Z}_0 the set of nonnegative integers, \mathbf{Q} the set of rational numbers, \mathbf{R} the set of real numbers, and \mathbf{R}_0 the set of nonnegative real numbers. Let X be a lattice of rank g , B an integral positive definite symmetric bilinear form on $X \times X$. Let $X_{\mathbf{Q}} = X \otimes_{\mathbf{Z}} \mathbf{Q}$ and $X_{\mathbf{R}} = X \otimes_{\mathbf{Z}} \mathbf{R}$. The bilinear form B determines a distance $\| \cdot \|_B$ on $X_{\mathbf{R}}$ by $\|x\|_B := \sqrt{B(x,x)}$ ($x \in X_{\mathbf{R}}$). For an arbitrary $\alpha \in X_{\mathbf{R}}$ we say that a lattice element $a \in X$ is α -nearest if

$$\|a - \alpha\|_B = \min\{\|b - \alpha\|_B; b \in X\}$$

We define a (closed) B -Delaunay cell σ (or simply a Delaunay cell if B is understood) to be the closed convex hull of all lattice elements which are α -nearest for some $\alpha \in X_{\mathbf{R}}$ for a fixed α . Note that for a given Delaunay cell σ , $\alpha \in \sigma$ is uniquely determined by σ , which we call *the hole* of σ and denote by $\alpha(\sigma)$. All the B -Delaunay cells constitute a locally finite decomposition of $X_{\mathbf{R}}$ into infinitely many bounded convex polyhedra, which we call the *Delaunay decomposition* Del_B .

Definition 2.1. In what follows we fix the bilinear form B , so we denote $B(x,y)$ simply by (x,y) , $B(x,x)$ by x^2 and the norm $\|x\|_B$ by $\|x\|$ if no confusion is possible. Let $\text{Del} := \text{Del}_B$ be the Delaunay

decomposition on $X_{\mathbf{R}}$ defined by the distance $\|x\| := \sqrt{B(x, x)}$. For any subset T of $X_{\mathbf{R}}$ let $\text{Del}(T)$ be the set of all Delaunay cells containing T , and $\text{Star}(T)$ the union of all $\sigma \in \text{Del}(T)$. In particular, for any $c \in X$, $\text{Del}(c)$ is the set of all the Delaunay cells containing $c \in X$ and $\text{Star}(c)$ is the union of all $\sigma \in \text{Del}(c)$. We note $\text{Del}(c) = c + \text{Del}(0)$, the translate of $\text{Del}(0)$ by c . We denote by $\text{Del}^{(k)}$ the set of Delaunay cells $\sigma \in \text{Del}$ such that $\dim \sigma = k$. Let $\text{Del}^{(k)}(T) = \text{Del}(T) \cap \text{Del}^{(k)}$. For a $\sigma \in \text{Del}$, we define Del_{σ} to be the set of all faces of σ and $\text{Del}_{\sigma}^{(k)} := \text{Del}^{(k)} \cap \text{Del}_{\sigma}$. For $\tau \in \text{Del}$, we define $\text{Del}_{\sigma}(\tau) := \text{Del}_{\sigma} \cap \text{Del}(\tau)$ and $\text{Del}_{\sigma}^{(k)}(\tau) := \text{Del}^{(k)} \cap \text{Del}_{\sigma}(\tau)$.

Definition 2.2. Let D be a subset of $X_{\mathbf{R}}$. If D contains the origin 0, we define $C(0, D)$ to be the cone over \mathbf{R}_0 generated by D , and define $\text{Semi}(0, D)$ to be the cone over \mathbf{Z}_0 generated by $D \cap X$. For any subset S of D we define $X(S)$ to be the subgroup of X generated by $s - t$, ($\forall s, t \in S$). We denote $X(S) \otimes \mathbf{R}$ by $X(S)_{\mathbf{R}}$. We also define

$$\begin{aligned} C(s, D) &:= s + C(0, D - s) \quad (\text{for } s \in D) \\ C(S, D) &:= \bigcup_{a \in X(S), s \in S \cap X} (a + C(s, D)) \\ &= X(S) + C(s_0, D) \quad (\forall s_0 \in S). \end{aligned}$$

If S is a one-codimensional face of a g -dimensional convex polytope D of $X_{\mathbf{R}}$, then S spans a hyperplane of $X_{\mathbf{R}}$, which we denote by $H(S)$, and $C(S, D)$ is a closed half space of $X_{\mathbf{R}}$ containing D bounded by $H(S)$.

In order to make this article as self-contained as possible. we give proofs for basic facts about Delaunay/Voronoi decompositions. See also [Nr99].

Definition 2.3. The Voronoi cell $V(0)$ at 0 is defined to be

$$V(0) = \{\alpha \in X_{\mathbf{R}}; \|y - \alpha\| \geq \|\alpha\| \text{ for any } y \in X\}.$$

Lemma 2.4. For any $x \in X$ the following are equivalent:

- (i) $x \in 2V(0) \cap X$, namely, $(y, y) \geq (x, y)$ for any $y \in X$,
- (ii) $x \in \text{Star}(0) \cap X$, namely, there is $\sigma \in \text{Del}(0)$ such that $x \in \sigma \cap X$.

Proof. Assume (i). Then $\|y - (x/2)\| \geq \|x/2\|$ for any $y \in X$, where the minimum of $\|y - (x/2)\|$ is attained at $y = 0$ and x . Hence (ii) follows.

Conversely if there is a Delaunay cell $\sigma \in \text{Del}(0)$ such that $x \in \sigma \cap X$, then there is an $\alpha \in X_{\mathbf{R}}$ such that $\|y - \alpha\|^2 \geq \|\alpha\|^2$ and $\|x - \alpha\|^2 = \|\alpha\|^2$. Hence $\alpha \in V(0)$. By the first inequality we have $\|-y + x - \alpha\|^2 \geq \|\alpha^2\|$ for

any y , from which it follows that $\|y\|^2 \geq 2(x-\alpha, y)$, namely, $x-\alpha \in V(0)$. Hence $x = \alpha + (x - \alpha) \in 2V(0)$. This proves (i). This proves the lemma. Q.E.D.

Lemma 2.5. *Let $a_i \in \text{Star}(0)$ ($1 \leq i \leq n$). Assume that there is $z (\neq 0) \in X$ such that $a_1 + \dots + a_n = mz$. Then $n \geq m$, equality holding if and only if $(z, z) = (a_i, z)$ for any i .*

Proof. Since $a_i \in \text{Star}(0)$, we have $y^2 \geq (a_i, y)$ for any $y \in X$ by Lemma 2.4. In particular, $z^2 \geq (a_i, z)$. It follows that $nz^2 \geq (a_1 + \dots + a_n, z) = mz^2$. Hence $n \geq m$. If $n = m$, then any inequality in the above is equality. This proves the lemma. Q.E.D.

Definition 2.6. We say that $x_1, \dots, x_m \in X$ ($x_i \neq x_j$) are cellmates if there is a Delaunay cell $\sigma \in \text{Del}$ that contains all of x_i . We say that $x_1, \dots, x_m \in \text{Star}(0)$ are cellmates at 0 if there is a Delaunay cell $\sigma \in \text{Del}(0)$ that contains all of x_i .

Lemma 2.7. *Let σ be a Delaunay cell and $z (\neq 0) \in X$. Then*

- (i) $\sigma \cap (mz + \sigma) = \emptyset$ for $m \geq 2$.
- (ii) $\text{Star}(0) \cap (mz + \text{Star}(0)) = \emptyset$ if $m \geq 3$.

Proof. Suppose that $c \in \sigma \cap X$ and $d = c + mz \in \sigma$ for some nonzero $z \in X$. Since c and d are cellmates, we have $c - d \in \text{Star}(0)$. Hence $mz \in \text{Star}(0)$. It follows from Lemma 2.5 that $m = 1$. This proves (i).

Next we prove (ii). Suppose $\text{Star}(0) \cap (mz + \text{Star}(0)) \neq \emptyset$. Then there are a, b and $z \in X$ such that $a - b = mz$ and $a, b \in \text{Star}(0)$. Then by Lemma 2.5 we have $m \leq 2$. This proves the assertion. Q.E.D..

Lemma 2.8. (i) *Let $\sigma \in \text{Del}(0)$ and $b \in C(0, \sigma) \cap X$. If $b \notin \sigma \cap X$, then there is $a \in \sigma \cap X$ such that $(b - a, a) > 0$.*

- (ii) *If $x \notin \text{Star}(0) \cap X$, then there exists $a \in \text{Star}(0) \cap X$ such that $\|x\|^2 > \|x - a\|^2 + \|a\|^2$.*

Proof. We prove (i). Let $b \in C(0, \sigma) \cap X$ and $\alpha(\sigma)$ the hole of σ . We assume $(b, a) \leq (a, a)$ for any $a \in \sigma \cap X$. Then we prove $b \in \sigma \cap X$. For this let $b = \sum_{i=1}^r r_i a_i$ for $a_i \in \sigma \cap X$ and some $r_i \geq 0$. We see

$$(b, b) = \sum_{i=1}^r r_i (b, a_i) \leq \sum_{i=1}^r r_i (a_i, a_i) = 2 \sum_{i=1}^r r_i (\alpha(\sigma), a_i) = 2(\alpha(\sigma), b)$$

whence $(b, b) = 2(\alpha(\sigma), b)$. It follows $b \in \sigma \cap X$.

We shall prove (ii). Let $x \in X$. Since $\text{Star}(0)$ contains an open neighborhood of the origin in $X_{\mathbf{R}}$, there is $\sigma \in \text{Del}(0)$ such that $x \in$

$C(0, \sigma) \cap X \setminus \sigma$. By (i) there exists $a \in \sigma \cap X$ such that $(x - a, a) > 0$. Hence $\|x\|^2 > \|x - a\|^2 + \|a\|^2$. Q.E.D.

Definition 2.9. We set

$$v(x) = \min\left\{\frac{1}{2} \sum_{i=1}^m (x_i, x_i); x = x_1 + \cdots + x_m, x_i \in X, m \geq 1\right\}$$

$$v(x, c) = v(x) + (x, c).$$

Lemma 2.10. Let $\sigma \in \text{Del}(0)$ and $\alpha(\sigma) \in \sigma$ the hole of σ . Then $v(x) \geq (x, \alpha(\sigma))$ for any $x \in X$, equality holding iff $x \in \text{Semi}(0, \sigma)$.

Proof. Choose $x_i \in X$ such that $x = x_1 + \cdots + x_m$ and $v(x) = \frac{1}{2} \sum_{i=1}^m (x_i, x_i)$. Then

$$\sum_{i=1}^m (x_i, x_i) \geq 2 \sum_{i=1}^m (x_i, \alpha(\sigma)) = 2(x, \alpha(\sigma)).$$

This proves $v(x) \geq (x, \alpha(\sigma))$. If $v(x) = (x, \alpha(\sigma))$, then we have $(x_i, x_i) = 2(x_i, \alpha(\sigma))$ for any i . The equality $(x_i, x_i) = 2(x_i, \alpha(\sigma))$ implies that $x_i \in \sigma \cap X$. This proves $x \in \text{Semi}(0, \sigma)$. Q.E.D.

§3. Degenerating families of abelian varieties — general case

Let R be a complete discrete valuation ring, q a uniformizing parameter of R , $k(0) = R/qR$ and $k(\eta)$ the fraction field of R , 0 the closed point and η the generic point of $\text{Spec } R$. The purpose of this section is to recall the (simplified) Mumford construction over R [AN99]. See also [M72].

Let X be a free \mathbf{Z} -module of rank g and $a(x) \in k(\eta)^\times := k(\eta) \setminus \{0\}$ for any $x \in X$.

Definition 3.1. Let $b(x, y) := a(x+y)a(x)^{-1}a(y)^{-1}$. If the following conditions are satisfied, $\{a(x); x \in X\}$ is called a (Faltings-Chai's) degeneration data :

- (i) $a(0) = 1$,
- (ii) $b(x, y)$ is a (multiplicatively) bilinear form on $X \times X$ with values in $k(\eta)^\times$,
- (iii) $B(x, y) := \text{val}_q b(x, y)$, a positive definite symmetric bilinear form of $X \times X$.

Definition 3.2. Let $\{a(x); x \in X\}$ be a degeneration data and $A(x) = \text{val}_q a(x)$. Let ϑ be an indeterminate over R , $R[\vartheta][X]$ the group algebra over $R[\vartheta]$ of the additive group $X (\simeq \mathbf{Z}^g)$. The algebra $R[\vartheta][X]$

is regarded as a graded algebra by setting $\deg(\vartheta) = 1$ and $\deg(a) = 0$ for any $a \in R[X]$.

We define a graded subalgebra \tilde{R} of $R[\vartheta][X]$ by

$$\tilde{R} := R[a(x)w^x\vartheta; x \in X] = R[\xi_x\vartheta; x \in X], \quad \xi_x := q^{A(x)}w^x.$$

Let $\tilde{Q} := \text{Proj}(\tilde{R})$. Let Y be a sublattice of X of finite index. Then Y acts on \tilde{Q} by

$$S_y^*(a(x)w^x\vartheta) = a(x+y)w^{x+y}\vartheta \quad \text{for } y \in Y.$$

The invertible sheaf $O_{\tilde{Q}}(1)$ is kept invariant by the action of Y .

Let \tilde{Q}_{for} be the formal completion of \tilde{Q} along $\tilde{Q}_0 := \text{Proj}(\tilde{R}/q\tilde{R})$. The induced action of Y on \tilde{Q}_{for} , which we denote also by S_y , is free. The invertible sheaf $O_{\tilde{Q}_{\text{for}}}(1)$ descends to an invertible sheaf L_{for} on the formal quotient \tilde{Q}_{for}/Y . This turns out to be ample on \tilde{Q}_{for}/Y . In fact, it is very ample on $\tilde{Q}_{\text{for}}/nY$ for any $n \geq 3$. See [Nr99, Theorem 6.2].

Hence by the algebrization theorem of Grothendieck we have

Theorem 3.3. *There is a projective R -scheme Q with an ample invertible sheaf L such that the formal completion of (Q, L) along the closed fibre is isomorphic to the pair $(\tilde{Q}_{\text{for}}/Y, O_{\tilde{Q}_{\text{for}}}(1)/Y)$. The generic fibre (Q_η, L_η) is a polarized abelian scheme by enlarging $k(\eta)$ if necessary.*

Proof. The last assertion about the generic fibre follows from [M72]. We omit the details because they are more or less well known. See also [AN99, Remark 3.10]. Q.E.D.

Proposition 3.4. *Let $(\tilde{Q}, \tilde{L}) = (\text{Proj } \tilde{R}, O_{\text{Proj } \tilde{R}}(1))$. Then*

- (i) \tilde{Q} is covered with open affine subschemes $W(c) := \text{Spec } S(c)$ where

$$S(c) := R[\xi_{x,c}; x \in X] \quad (c \in X), \quad \xi_{x,c} := \xi_{x+c}/\xi_c$$

- (ii) *The coordinate ring $S(c)$ of $W(c)$ is an R -algebra of finite type generated by $\xi_{x,c}$ ($x \in \text{Star}(0) \cap X$). All the ring $S(c)$ are isomorphic to each other as R -algebras. The isomorphism $\phi_{c,d} : S(d) \rightarrow S(c)$ is given by $\phi_{c,d}(\xi_{x+d}/\xi_d) = \xi_{x+c}/\xi_c$ for any $x \in X$.*

Remark 3.5. For a given abelian scheme G over R with G_0 a split torus over $k(0)$, we can construct a degeneration data $\{a(x); x \in X\}$ by taking a finite base change when necessary. Let G_{for} be the formal

completion of G along the closed fibre G_0 . Then G_{for} is proved to be isomorphic to a formal split torus $\mathbf{G}_{m,\text{for}}^g$ over R . In that case, X is the character group of G_{for} while Y is the character group of the formal completion of the dual abelian scheme of G . Letting $A(x) = \text{val}_q a(x)$, we see $A(x+y) - A(x) - A(y) = B(x, y)$. Hence $A(x) - \frac{1}{2}B(x, x)$ is linear in x , which we can write as $\frac{1}{2}r$ for some $r \in \text{Hom}(X, \mathbf{Z})$. By furthermore taking pull back of the family by replacing R by $R[s]$ with $s^2 = q$ if necessary, we may assume $B(x, x)$ and $r(x)$ are even-integers for any $x \in X$. Then by choosing $u^x = w^x s^{r(x)}$ instead of w^x (the coordinates of the formal torus $\mathbf{G}_{m,\text{for}}^g$), we may assume $A(x) = \frac{1}{2}B(x, x)$ and it is integer-valued on X . This assumption is harmless for our study of the closed fibres (Q_0, L_0) because the closed fibres are unchanged by the pull back and we study only cohomology groups of the closed fibres. Therefore in what follows we assume

- (i) $B(x, x)$ is even for any $x \in X$
- (ii) $A(x) = \frac{1}{2}B(x, x)$, $r(x) = 0$.

Definition 3.6. With the notation in Definition 2.9, we define

$$\begin{aligned} \xi(x, c) &= q^{v(x,c)} w^x = q^{v(x)+(x,c)} w^x \in \Gamma(W(c), O_{\bar{Q}}), \\ \bar{\xi}(x, c) &:= \xi(x, c) \otimes k(0), \quad \bar{\xi}(x) := \xi(x, 0) \in \Gamma(W(0), O_{\bar{Q}}). \end{aligned}$$

We define $R(c) = S(c) \otimes k(0)$ and $U(c) = W(c) \otimes k(0) = \text{Spec } R(c)$. We also set $\bar{\xi}(x) := \xi(x) \otimes k(0)$. It is clear that

$$\Gamma(U(c), O_{U(c)}) = R(c) = \bigoplus_{x \in X} k(0) \cdot \bar{\xi}(x, c).$$

With the above notation, $\phi_{c,d}(\xi(x, d)) = \xi(x, c)$ for any $x \in X$.

Lemma 3.7. Let $\bar{\xi}(x) := \xi(x) \otimes k(0) \in S(0) \otimes k(0)$ ($x \in X$).

- (i) If $x \notin \text{Star}(0) \cap X$, then $\bar{\xi}(x) = 0$.
- (ii) If $x_1, \dots, x_m \in \text{Star}(0)$ are not cellmates at 0, then the product $\bar{\xi}(x_1) \cdots \bar{\xi}(x_m)$ is either zero or nilpotent.

Proof. By Lemma 2.8 (ii) ξ_x is divisible by $q\xi_{x-a}\xi_a$ in $S(0)$, which proves (i). Next we prove (ii). Let $x = x_1 + \cdots + x_m$. Choose $\sigma \in \text{Del}(0)$ such that $x \in C(0, \sigma)$, and let $\alpha(\sigma) \in \sigma$ be the hole of σ . Then there exist some positive integers $n \in \mathbf{Z}_+$, $n_i \in \mathbf{Z}_+$ and $a_i \in \sigma \cap X$ such that $nx = n_1 a_1 + \cdots + n_r a_r$. We have

$$\begin{aligned} n \sum_{i=1}^m (x_i, x_i) &\geq 2n(\alpha(\sigma), \sum_{i=1}^m x_i) = 2(\alpha(\sigma), nx) \\ &= 2 \sum_{i=1}^r n_i (\alpha(\sigma), a_i) = \sum_{i=1}^r n_i (a_i, a_i). \end{aligned}$$

Since x_i are not cellmates at 0, there is at least an x_i such that $x_i \notin \sigma$, hence $(x_i, x_i) > 2(\alpha(\sigma), x_i)$. Therefore the above inequality is strict. This proves (ii). Q.E.D.

Lemma 3.8. $U(c_0) \cap U(c_1) \cap \cdots \cap U(c_q) \neq \emptyset$ iff c_0, c_1, \dots, c_q are cellmates.

Proof. If c_0, c_1, \dots, c_q are cellmates, then it is clear that $U(c_0) \cap U(c_1) \cap \cdots \cap U(c_q) \neq \emptyset$. We shall prove the converse. We suppose that $U(c_0) \cap U(c_1) \cap \cdots \cap U(c_q) \neq \emptyset$ and that c_0, c_1, \dots, c_q are not cellmates to derive a contradiction. We may assume $c_0 = 0$ without loss of generality. We note any $\bar{\xi}_{c_i}$ is invertible on $U(c_0) \cap U(c_1) \cap \cdots \cap U(c_q)$. If there is some c_i ($i > 0$) such that $c_i \notin \text{Star}(0)$, then $\bar{\xi}_{c_i} = 0$ by Corollary 3.7, a contradiction. If $c_i \in \text{Star}(0)$ for any $i > 0$, the product $\bar{\xi}_{c_1} \cdots \bar{\xi}_{c_q}$ is zero or nilpotent by Corollary 3.7, which contradicts that $\bar{\xi}_{c_i}$ is invertible on the nonempty set $U(c_0) \cap U(c_1) \cap \cdots \cap U(c_q)$. This prove the lemma. Q.E.D.

From Lemma 2.7 (ii) and Lemma 3.8 we infer

Corollary 3.9. (i) $U(c)$ ($c \in X$) is an affine covering of \tilde{Q}_0 .
 (ii) If $Y \subset mX$ for some $m \geq 3$, then $U(c) \cap U(c+y) = \emptyset$ for nonzero $y \in Y$, and $U(c)$ ($c \in X/Y$) is an affine covering of Q_0 .

Lemma 3.8 gives a direct proof of the following

Theorem 3.10. Let $\mathbf{G}_m^g := \text{Spec } k(0)[w^x; x \in X]$. Then there is a natural action of \mathbf{G}_m^g on \tilde{Q}_0 . For any Delaunay cell σ we define

$$V(\sigma) := \text{Proj } k(0)[\bar{\xi}_a; a \in \sigma \cap X],$$

$$O(\sigma) := \text{Spec } k(0)[\bar{\xi}_a/\bar{\xi}_b; a, b \in \sigma \cap X].$$

Then

- (i) $O(\sigma)$ is the unique closed \mathbf{G}_m^g -orbit in $\bigcap_{c \in \sigma \cap X} U(c)_{\text{red}}$,
- (ii) $\tilde{Q}_{0,\text{red}} = \bigcup_{\sigma \in \text{Del}} O(\sigma)$ with $O(\sigma) \cap O(\tau) = \emptyset$ for $\sigma \neq \tau$ and $\sigma, \tau \in \text{Del}$.
- (iii) $V(\sigma)$ is naturally a closed reduced subscheme of \tilde{Q}_0 of $\dim V(\sigma) = \dim \sigma$, which is the closure of $O(\sigma)$.
- (iv) Let $\tau, \sigma \in \text{Del}$. Then $V(\tau) \subset V(\sigma)$ iff $\tau \subset \sigma$.

Proof. We may assume $c_0 = 0 \in \sigma \cap X$ without loss of generality. First we note \mathbf{G}_m^g acts on \tilde{Q}_0 by $S_a^*(q^A w^x) = a^x q^A w^x$ for any T -valued point $a \in \mathbf{G}_m^g(T)$. By the definition

$$\Gamma(O_{O(\sigma)}) = k(0)[\bar{\xi}_a/\bar{\xi}_b; a, b \in \sigma \cap X].$$

By Lemma 3.8

$$\begin{aligned} \bigcap_{c \in \sigma \cap X} U(c)_{\text{red}} &= \text{Spec } k(0)[\bar{\xi}_x/\bar{\xi}_b; x \in X, b \in \sigma \cap X]/\sqrt{(0)} \\ &= \text{Spec } \Gamma(O_{O(\sigma)})[\bar{\xi}_x; x \in \text{Star}(\sigma) \cap X]/\sqrt{(0)} \\ &= \text{Spec } \Gamma(O_{O(\sigma)})[\bar{\xi}_x; x \in (\text{Star}(\sigma) \setminus \sigma) \cap X]/\sqrt{(0)}. \end{aligned}$$

Its unique closed orbit is given by the equations

$$\bar{\xi}_x = 0 \quad (\forall x \in (\text{Star}(\sigma) \setminus \sigma) \cap X).$$

Thus the assertions (i) and (ii) are clear from the above description. The assertion (iii) except its reducedness is clear from the definition of Proj.

We prove that $V(\sigma)$ is a reduced subscheme of \tilde{Q}_0 . Because the affine coordinate ring $\Gamma(O_{V(\sigma) \cap U(0)})$ of $V(\sigma) \cap U(0)$ is $k(0)[\bar{\xi}_x; x \in \sigma \cap X]$. Any nontrivial monomial of weight $x \in X$ in it is a product of $\bar{\xi}_{x_i}$ with cellmates $x_i \in \sigma \cap X$. By Corollary 3.7 it is $q^{(x, \alpha(\sigma))} w^x$, whence $\Gamma(O_{V(\sigma) \cap U(0)})$ has no nilpotent elements.

Next we prove (iv). Let $\{c_0 = 0, c_1, \dots, c_q\} = \tau \cap X$. Let $U(\tau) := \bigcap_{c \in \tau \cap X} U(c)$. Suppose $\tau \subset \sigma$. First we note $V(\sigma) \cap U(\tau) = V(\sigma)_{\text{red}} \cap U(\tau) = V(\sigma)_{\text{red}} \cap U(\tau)_{\text{red}}$. We also see

$$\Gamma(O_{U(\tau)_{\text{red}}}) = \Gamma(O_{O(\tau)})[\bar{\xi}_x; x \in (\text{Star}(\tau) \setminus \tau) \cap X]/\sqrt{(0)}$$

The closed subscheme $V(\sigma) \cap U(\tau)$ of $U(\tau)$ is defined by the ideal $(\bar{\xi}_x; x \in (\text{Star}(\tau) \setminus \sigma) \cap X)$, while $O(\tau)$ is defined by the ideal $(\bar{\xi}_x; x \in (\text{Star}(\tau) \setminus \tau) \cap X)$. By the assumption $\tau \subset \sigma$, $V(\sigma) \cap U(\tau)$ contains $O(\tau)$, whence $V(\sigma) \supset V(\tau)$.

Next we assume $\tau \not\subset \sigma$ to prove $V(\tau) \not\subset V(\sigma)$. Then there is $a \in \tau \cap X$ such that $a \notin \sigma$. Then $V(\tau) \cap U(a) = \text{Spec } k(0)[\bar{\xi}_x/\bar{\xi}_a, x \in \tau \cap X]$. Let p_a be a closed point of $U(a)$ defined by $\bar{\xi}_x/\bar{\xi}_a = 0$ for any $x (\neq a) \in X$. Hence $p_a \notin U(x)$ for any $x \neq a$. Since $V(\sigma)$ is covered with $U(b)$ ($b \in \sigma \cap X$), this shows that $p_a \notin V(\sigma)$. This implies $V(\tau) \not\subset V(\sigma)$. This completes the proof of (iv), hence of the lemma. Q.E.D.

§4. Outline of the proof of Theorem 1

The purpose of this section is not to give a proof of Theorem 1 (Theorem 5.17), but to explain the outline of it.

For simplicity we assume $Y \subset mX$ for some $m \geq 3$.

Under the assumption $S_y(U(c)) \cap U(c) = \emptyset$ for any $c \in X$ and $y \in Y \setminus \{0\}$ and $U(c)$ ($c \in X/Y$) is an affine covering of Q_0 in view

of Corollary 3.9. Therefore the cohomology groups $H^q(Q_0, L_0^n)$ are computed by using the Čech cohomology relative to the covering $U(c)$ ($c \in X/Y$).

4.1. The particular case where Q_0 is reduced

First we consider the particular case when $k(0) \subset R$ and (\tilde{Q}, \tilde{L}) is the pull back of a normal torus embedding locally of finite type over $k(0)$ by the inclusion of $\text{Spec } R$ into $\text{Spec } k(0)[q]$. Then $(Q, L) = (P, L)$ with the notation of [Nr99]. We recall the proof of $H^q(Q_0, L_0^n) = 0$ for $q, n > 0$ from [Nr99].

First we have an exact sequence of O_{Q_0} -modules

$$(1) \quad 0 \rightarrow O_{Q_0} \rightarrow \bigoplus O_{V(\sigma_g)} \xrightarrow{\partial_g} \dots \xrightarrow{\partial_2} \bigoplus O_{V(\sigma_1)} \xrightarrow{\partial_1} \bigoplus O_{V(\sigma_0)} \rightarrow 0$$

where σ_i ranges over the set of all i -dimensional Delaunay cells mod Y . The homomorphism $\partial_i : \bigoplus O_{V(\sigma_i)} \rightarrow \bigoplus O_{V(\sigma_{i-1})}$ in the above is defined by

$$\partial_i \left(\bigoplus_{\sigma \in \text{Del}^{(i)}} \phi_\sigma \right) = \bigoplus_{\tau \in \text{Del}^{(i-1)}} \sum_{\tau \subset \sigma} [\sigma : \tau] \phi_\sigma,$$

where the summation $\sum_{\tau \subset \sigma}$ runs over the set of all i -dimensional Delaunay cells σ containing a fixed τ as a face of codimension one, and any Delaunay cell σ is oriented and $[\sigma : \tau] (= \pm 1)$ is the incidence number of σ relative to τ . Then by tensoring (1) with L_0^n we have an exact sequence

$$0 \rightarrow L_0^n \otimes O_{P_0} \rightarrow \bigoplus L_0^n \otimes O_{V(\sigma_g)} \xrightarrow{\partial_g} \dots \xrightarrow{\partial_1} \bigoplus L_0^n \otimes O_{V(\sigma_0)} \rightarrow 0.$$

Now the proof of $H^q(Q_0, L_0^n) = 0$ goes as follows.

(i) Since $V(\sigma)$ is a normal torus embedding with L_0 ample, we have

$$H^q(V(\sigma), L_0^n) = \begin{cases} \bigoplus_{\frac{x}{n} \in \sigma \cap \frac{X}{n}} k(0) \cdot [x] & \text{if } q = 0 \\ 0 & \text{if } q > 0 \end{cases}$$

where $[x]$ is a certain monomial in $\tilde{R}/q\tilde{R}$ of weight x .

(ii) By (i) $H^*(P_0, L_0^n)$ is the cohomology of the complex

$$0 \rightarrow \bigoplus \Gamma(V(\sigma_g), L_0^n) \xrightarrow{H^0(\partial_g)} \dots \xrightarrow{H^0(\partial_1)} \bigoplus \Gamma(V(\sigma_0), L_0^n) \rightarrow 0.$$

(iii) By (i) and (ii)

$$H^q(Q_0, L_0^n) \simeq \bigoplus_{\frac{x}{n} \in \frac{X}{n} \text{ mod } Y} H^q(\text{Star}(\frac{x}{n})^0, k(0)) = 0 \text{ for } q, n > 0$$

where $\text{Star}(a)$ denotes the union of $\sigma \in \text{Del}(a)$, and $\text{Star}(a)^0$ denotes the relative interior of $\text{Star}(a)$. The subset $\text{Star}(a)^0$ of $X_{\mathbf{R}}$ is connected and contractible.

4.2. The general case

In the case where Q_0 is possibly nonreduced or (Q, L) may not come from a torus embedding, we have no exact sequences like (1). Nevertheless we can imitate the above proof of $H^q(Q_0, L_0^n) = 0$.

We will construct a double complex $({}_nC', \Delta_n)$ for each positive integer n such that

$$\begin{aligned} {}_nC' &= \bigoplus {}_nC^p, & {}_nC^p &= \bigoplus_{k+q=p} {}_nF^{k,q}, & \Delta_n^p &= \bigoplus_{k+q=p} (\partial^{k,q} + (-1)^q \delta_n^{k,q}), \\ {}_nF^{k,q} &= \bigoplus_{\sigma \in \text{Del}(g^{-k}) \bmod Y} {}_nF_{\sigma}^{k,q} = \bigoplus_{\sigma \in \text{Del}(g^{-k}) \bmod Y} \left(\bigoplus_{x \in X} {}_nF_{\sigma}^{k,q}[x] \right) \end{aligned}$$

where ${}_nF_{\sigma}^{k,q}[x]$ is the weight x -part of ${}_nF_{\sigma}^{k,q}$. We see

$$\Delta_n^{p+1} \cdot \Delta_n^p = 0, \quad \partial^{k+1,q} \cdot \partial^{k,q} = 0, \quad \delta_n^{k,q+1} \cdot \delta_n^{k,q} = 0.$$

Then our new proof goes as follows.

(a)

$${}'' E_2^{k,q} = \begin{cases} H^q(Q_0, L_0^n) & \text{if } k = 0 \\ 0 & \text{if } k > 0 \end{cases}$$

(b)

$$H^q({}_nF_{\sigma}^{k,\cdot}, \delta_n^{k,\cdot}) = \begin{cases} \bigoplus_{\frac{x}{n} \in \sigma \cap \frac{X}{n}} k(0) \cdot [x] & \text{if } q = 0 \\ 0 & \text{if } q > 0 \end{cases}$$

where $[x]$ is a certain monomial in $\tilde{R}/q\tilde{R}$ of weight x .

(c) By (b)

$$\begin{aligned} {}' E_1^{k,q} &= H^q({}_nF^{k,\cdot}, \delta_n^{k,\cdot}) = \bigoplus_{\sigma \in \text{Del}(g^{-k}) \bmod Y} H^q({}_nF_{\sigma}^{k,\cdot}, \delta_n^{k,\cdot}) \\ &= \begin{cases} \bigoplus_{\sigma \in \text{Del}(g^{-k}) \bmod Y} \left(\bigoplus_{\frac{x}{n} \in \sigma \cap \frac{X}{n}} k(0) \cdot [x] \right) & \text{if } q = 0 \\ 0 & \text{if } q > 0. \end{cases} \end{aligned}$$

(d) By (c)

$${}'E_2^{k,q} = \begin{cases} \bigoplus_{\frac{x}{n} \in \frac{X}{n} \bmod Y} H^k(\text{Star}(\frac{x}{n})^0, k(0)) & \text{if } q = 0 \\ 0 & \text{if } q > 0. \end{cases}$$

(e) By (a) and (d)

$$\begin{aligned} H^q(Q_0, L_0^n) &= {}''E_2^{0,q} = \mathbf{H}^q({}_nC, \Delta_n) = {}'E_2^{q,0} \\ &= \bigoplus_{\frac{x}{n} \in \frac{X}{n} \bmod Y} H^q(\text{Star}(\frac{x}{n})^0, k(0)) = 0 \text{ if } q > 0. \end{aligned}$$

The hardest in the above is the part (b), which is an alternative for the part (i) in the first particular case. The assertion (b) is proved by using Lemma 4.3 (or Theorem 5.15)

$$H^q({}_nF_\sigma^{k,\cdot}[x], \delta_n^{k,\cdot}) = H^q(\Delta(\sigma), B_{\Delta(\sigma)}(\frac{x}{n})) = \begin{cases} k(0) & \text{if } q = 0, \frac{x}{n} \in \sigma \\ 0 & \text{otherwise} \end{cases}$$

where ${}_nF_\sigma^{k,q}[x]$ is the weight x -part of ${}_nF_\sigma^{k,q}$. See also Theorem 6.11.

Lemma 4.3. *Let $\sigma \in \text{Del}^{(g-k)}$. Let $\Delta(\sigma)$ be the abstract simplex with vertices $\sigma \cap X$. Then there is a subset $B_{\Delta(\sigma)}(\frac{x}{n})$ of $\Delta(\sigma)$ such that*

$$H^q({}_nF_\sigma^{k,\cdot}[x], \delta_n^{k,\cdot}) = H^q(\Delta(\sigma), B_{\Delta(\sigma)}(\frac{x}{n})).$$

Moreover

- (i) if $B_{\Delta(\sigma)}(\frac{x}{n})$ is nonempty, then it is connected and contractible.
- (ii) $B_{\Delta(\sigma)}(\frac{x}{n})$ is empty iff $\frac{x}{n} \in \sigma$.

This lemma is obtained by combining Lemma 6.10 and Theorem 6.11.

§5. Proof of Theorem 1

The purpose of this section is to prove Theorem 1 (Theorem 5.17). For simplicity we first assume

$$Y \subset mX \text{ for some } m \geq 3.$$

In what follows we denote $\bar{\xi}(x, c)$ by $\xi(x, c)$ if no confusion is possible.

Definition 5.1. Let $c \in X$. Let $R(c) = S(c) \otimes k(0) = \Gamma(O_{U(c)})$. For a Delaunay cell σ containing c , we define $k(0)$ -modules

$$F_\sigma(c) = \bigoplus_{x \in C(0, \sigma - c) \cap X} k(0) \cdot \xi(x, c),$$

$$F^k(c) = \bigoplus_{\sigma \in \text{Del}^{(g-k)}(c)} F_\sigma(c).$$

It should be mentioned that $F_\sigma(c)$ is not an $R(c)$ -module in general, though $F^k(c)$ is an $R(c)$ -module. Nevertheless we imitate the way of computing $H^q(P_0, L_0^n)$ in [Nr99, Theorem 3.9] and construct, by replacing O_{P_0} -modules $L_0^n \otimes O_{V(\sigma) \cap U(c)}$ [*ibid.*] by analogous $k(0)$ -modules, a double complex $F^{k,q}$ whose first row $F^{k,0}(c)$ at c is a resolution of $R(c)$ ($c \in X$).

Any $\phi_\sigma \in F_\sigma(c)$ is written

$$\phi_\sigma = \sum_{x \in C(0, \sigma - c) \cap X} a_\sigma(x, c) \xi(x, c), \quad (a_\sigma(x, c) \in k(0)).$$

Then we define

$$\text{res}_\tau^\sigma(\phi_\sigma) = \sum_{x \in C(0, \tau - c) \cap X} a_\sigma(x, c) \xi(x, c).$$

We also define $\partial^k : F^k(c) \rightarrow F^{k+1}(c)$ by

$$\partial^k \left(\bigoplus_{\sigma \in \text{Del}^{(g-k)}(c)} \phi_\sigma \right) = \bigoplus_{\tau \in \text{Del}^{(g-k-1)}(c)} \sum_{\tau \subset \sigma} [\sigma : \tau] \text{res}_\tau^\sigma(\phi_\sigma)$$

where $\phi_\sigma \in F_\sigma(c)$, and the summation in RHS ranges over the set of all σ containing a fixed τ as a face of codimension one.

Lemma 5.2. *There is an exact sequence of $k(0)$ -modules*

$$0 \rightarrow R(c) \rightarrow F^0(c) \xrightarrow{\partial^0} F^1(c) \xrightarrow{\partial^1} \dots \xrightarrow{\partial^{g-2}} F^{g-1}(c) \xrightarrow{\partial^{g-1}} F^g(c) \rightarrow 0$$

where $F^g(c) = k(0) \cdot \xi(0, c)$.

Proof. Let $f \in F^0(c)$. Then f is written as

$$f = \sum_{\sigma \in \text{Del}^{(g)}(c)} \left(\sum_{x \in C(0, \sigma - c) \cap X} a_\sigma(x, c) \xi(x, c) \right).$$

Then we see that $f \in \text{Ker}(\partial^0)$ if and only if $a_\sigma(x, c) = a_{\sigma'}(x, c)$ for any adjacent pair $\sigma, \sigma' \in \text{Del}^{(g)}(c)$ and any $x \in C(0, (\sigma \cap \sigma') - c) \cap X$. It follows that $R(c) = \text{Ker}(\partial^0)$. We denote $R(c)_x = k(0)\xi(x, c)$.

The exactness of the rest of the sequence is proved as follows. Now we choose and fix any $x \in X$ for all. For $\sigma \in \text{Del}^{(g-k)}(c)$ we define

$$F_\sigma(c)_x := \begin{cases} k(0) \cdot \xi(x, c) & \text{if } x \in C(0, \sigma - c) \cap X \\ 0 & \text{(otherwise)} \end{cases}$$

and

$$F^k(c)_x := \bigoplus_{\substack{\sigma \in \text{Del}^{(g-k)}(c) \\ x \in C(0, \sigma - c)}} F_\sigma(c)_x.$$

Note that $\partial^{g-k}(F^k(c)_x) \subset F^{k+1}(c)_x$. Now we define the complex $(F^\cdot(c)_x, \partial_{|F^\cdot(c)_x}^\cdot)$ by

$$F^0(c)_x \xrightarrow{\partial^0} F^1(c)_x \xrightarrow{\partial^1} \dots \xrightarrow{\partial^{g-2}} F^{g-1}(c)_x \xrightarrow{\partial^{g-1}} F^g(c)_x \rightarrow 0.$$

It remains to prove the exactness of the complex $(F^\cdot(c)_x, \partial_{|F^\cdot(c)_x}^\cdot)$ for each $x \in X$.

There is a Delaunay cell $\sigma \in \text{Del}(c)$ such that the relative interior of $C(0, \sigma - c)$ contains x . The Delaunay cell σ is uniquely determined by the given x , which we denote $\sigma_{\min}(x, c)$. We note that for $\sigma \in \text{Del}(c)$, $x \in C(0, \sigma - c)$ if and only if $\sigma_{\min}(x, c) \subset \sigma$. Let $\text{Del}(x, c)$ be the set of Delaunay cells $\sigma \in \text{Del}(c)$ such that $\sigma_{\min}(x, c) \subset \sigma$, and $\text{Del}^{(k)}(x, c) = \text{Del}(x, c) \cap \text{Del}^{(k)}$. Let $\text{Star}(x, c)$ be the union of $\sigma \in \text{Del}(x, c)$, $\sigma_{\min}(x, c)^\perp$ the affine linear subspace of $X_{\mathbf{R}}$ passing through x , perpendicular to $\sigma_{\min}(x, c)$. Let $\text{Star}^\perp(x, c)$ be the intersection $\text{Star}(x, c) \cap \sigma_{\min}(x, c)^\perp$, $\partial \text{Star}^\perp(x, c)$ the boundary of $\text{Star}^\perp(x, c)$. We note $\text{Star}(x, c) = \text{Star}(\sigma_{\min}(x, c))$. Let \mathbf{B} be a closed ball of dimension $g - \dim \sigma_{\min}(x, c)$, $\partial \mathbf{B}$ its boundary. Since $(\text{Star}^\perp(x, c), \partial \text{Star}^\perp(x, c))$ is homeomorphic to $(\mathbf{B}, \partial \mathbf{B})$, we have an isomorphism

$$H_q(\text{Star}^\perp(x, c), \partial \text{Star}^\perp(x, c), k(0)) = \begin{cases} k(0) & \text{if } q = g - \dim \sigma_{\min}(x, c) \\ 0 & \text{(otherwise)} \end{cases}$$

For the chosen and fixed x and c , we introduce a new complex $(G., \delta.)$ by

$$G_q := \bigoplus_{\sigma \in \text{Del}^{(q)}(x, c)} k(0) \cdot \sigma$$

$$\delta_q \left(\bigoplus_{\sigma \in \text{Del}^{(q)}(x, c)} a_\sigma \sigma \right) = \bigoplus_{\tau \in \text{Del}^{(q-1)}(x, c)} \left(\sum_{\tau \subset \sigma} [\sigma : \tau] a_\sigma \right) \tau.$$

When σ ranges over $\text{Del}(x, c)$, $\sigma \cap \sigma_{\min}(x, c)^\perp$ gives a cell decomposition of $\text{Star}^\perp(x, c)$. Since $(G., \delta.)$ is the relative chain complex of

$$(\text{Star}^\perp(x, c), \partial \text{Star}^\perp(x, c))$$

with coefficients in $k(0)$ whose degree is shifted by $\dim \sigma_{\min}(x, c)$, we have an isomorphism

$$\begin{aligned} \mathbf{H}_q(G., \delta.) &\simeq H_{q - \dim \sigma_{\min}(x, c)}(\text{Star}^\perp(x, c), \partial \text{Star}^\perp(x, c), k(0)) \\ &= \begin{cases} k(0) & \text{if } q = g \\ 0 & \text{(otherwise)} \end{cases} \end{aligned}$$

Suppose $\sigma \in \text{Del}^{(q)}$. By the definition of $G.$,

$$\begin{aligned} F_\sigma^{g-q}(c)_x = k(0)\xi(x, c) &\iff x \in C(0, \sigma - c) \cap X \\ &\iff \sigma_{\min}(x, c) \subset \sigma \\ &\iff \sigma \in \text{Del}^{(q)}(x, c) \iff k(0) \cdot \sigma \subset G_q \end{aligned}$$

Hence $(G_q, \delta_q) = (F^{g-q}(c)_x, \partial^{g-q})$. It follows

$$\mathbf{H}^q(F^\cdot(c)_x, \partial^\cdot) = \mathbf{H}_{g-q}(G., \delta.) = \begin{cases} k(0) & \text{if } q = 0 \\ 0 & \text{if } q > 0. \end{cases}$$

This proves the exactness of $(F^\cdot(c)_x, \partial^\cdot)$ except at $q = 0$, which completes the proof of the lemma. We note $H^0(F^\cdot(c)_x, \partial^\cdot) = R(c)_x := k(0)\xi(x, c)$. Q.E.D.

Definition 5.3. Let $\mathbf{c} = (c_0, c_1, \dots, c_q)$ ($c_i \neq c_j$) be an *ordered* set of cellmates, and $|\mathbf{c}| = \{c_0, c_1, \dots, c_q\}$ an unordered set of cellmates. Then we define

$$\begin{aligned} U(\mathbf{c}) &= U(c_0, c_1, \dots, c_q) := U(c_0) \cap U(c_1) \cap U(c_2) \cap \dots \cap U(c_q), \\ R(\mathbf{c}) &= R(c_0, c_1, \dots, c_q) := \Gamma(U(\mathbf{c}), O_{U(\mathbf{c})}) \end{aligned}$$

and

$$C^q := \bigoplus_{\substack{(c_0, c_1, \dots, c_q) \\ c_j : \text{cellmates}}} R(c_0, c_1, \dots, c_q).$$

We denote the set $\{c_0, c_1, \dots, c_q\}$ by $|\mathbf{c}|$. Let $X(\mathbf{c}) := X(|\mathbf{c}|) = \mathbf{Z}(c_1 - c_0) + \dots + \mathbf{Z}(c_q - c_0)$ and we define

$$k(0)[X(\mathbf{c})] = k(0)\left[\left(\frac{\bar{\xi}_{c_1}}{\bar{\xi}_{c_0}}\right)^{\pm 1}, \dots, \left(\frac{\bar{\xi}_{c_q}}{\bar{\xi}_{c_0}}\right)^{\pm 1}\right] \text{ (resp. } 0)$$

if c_0, c_1, \dots, c_q are cellmates (resp. if c_0, c_1, \dots, c_q are not cellmates).

Remark 5.4. We denote the set $\{c_0, c_1, \dots, c_q\}$ by $|\mathbf{c}|$. Lemma 3.8 shows that $U(\mathbf{c}) \neq \emptyset$ iff c_0, c_1, \dots, c_q are cellmates. Hence if c_j are cellmates and if $|\mathbf{c}| = \sigma \cap X$ for some $\sigma \in \text{Del}$, then by Theorem 3.10, $O(\sigma)$ is the unique closed \mathbf{G}_m^g -orbit in $U(\mathbf{c})_{\text{red}}$ with $\Gamma(O_{O(\sigma)}) = k(0)[X(\mathbf{c})]$. If c_0, c_1, \dots, c_q are not cellmates, then the product $f := \prod_{j=1}^q (\bar{\xi}_{c_j} / \bar{\xi}_{c_0})$ is nilpotent. This contradicts that f has the inverse in $k(0)[X(\mathbf{c})]$. This is why we define $k(0)[X(\mathbf{c})] := 0$ in the case. We also note that $\dim \sigma \geq \text{rank } X(\mathbf{c})$ if $|\mathbf{c}| \subset \sigma \in \text{Del}$, where equality may not be true in general.

Lemma 5.5. *Let τ be a Delaunay cell and $\alpha(\tau) \in \tau$ the hole of τ . Let $\mathbf{c} = (c_0, c_1, \dots, c_q)$. Assume $|\mathbf{c}| \subset \tau$. Then*

$$k(0)[X(\mathbf{c})] = k(0)[q^{(a, \alpha(\tau))} w^a; a \in X(\mathbf{c})].$$

Proof. By the assumption, $\|c_0 - \alpha(\tau)\| = \|c_j - \alpha(\tau)\|$, whence $c_j^2 - 2(c_j, \alpha(\tau)) = c_0^2 - 2(c_0, \alpha(\tau))$ for any j . Hence $\bar{\xi}_{c_j} / \bar{\xi}_{c_0} = q^{(c_j - c_0, \alpha(\tau))} w^{c_j - c_0}$.
 Q.E.D.

Lemma 5.6. *Let $\mathbf{c} = (c_0, c_1, \dots, c_q)$ with c_i cellmates, $\text{Star}(\mathbf{c}) := \text{Star}(|\mathbf{c}|)$. Let $\sigma \in \text{Del}$ and $C(c_0, \sigma)^0$ the relative interior of $C(c_0, \sigma)$. For any class $(x \bmod X(\mathbf{c}))$*

- (i) *there is $x' \in C(0, \text{Star}(\mathbf{c}) - c_0)^0$ such that $x' \equiv x \bmod X(\mathbf{c})$.*
- (ii) *If $x' + c_0 \in C(c_0, \text{Star}(\mathbf{c}))^0$ and $x' \equiv x \bmod X(\mathbf{c})$, then there is the unique Delaunay cell σ such that $|\mathbf{c}| \subset \sigma$ and $x' + c_0 \in C(c_0, \sigma)^0$.*
- (iii) *The above Delaunay cell σ is uniquely determined by the given class $x \bmod X(\mathbf{c})$, independent of the choice of x' with $x' + c_0 \in C(c_0, \sigma)^0$.*

We denote by $\sigma_{\min}(x, \mathbf{c})$ the unique Delaunay cell satisfying the condition (ii).

Proof. We recall $\text{Star}(c_j)$ is the union of all the Delaunay cells containing c_j , which is bounded convex. Hence $\text{Star}(\mathbf{c}) = \bigcap_{j=0}^q \text{Star}(c_j)$ is a *bounded* convex subset of $X_{\mathbf{R}}$. Therefore $C(c_0, \text{Star}(\mathbf{c}))$ is a convex closed subset of $X_{\mathbf{R}}$ given by finitely many (affine-)linear inequalities:

$$C(c_0, \text{Star}(\mathbf{c})) = \{x \in X_{\mathbf{R}}; F_j(x) \geq 0 \ (j = 1, \dots, N)\}$$

where $F_j(c_0) = 0$, $F_j(c_k) \geq 0$ ($\forall j, k$). We note $F_j(c_k) > 0$ ($\exists k \geq 1$) for each j because $\text{Star}(\mathbf{c})$ is bounded with $\dim \text{Star}(\mathbf{c}) = g$. Since $F_j(x)$ is linear in $x - c_0$, $F_j(x) = (A_j, x - c_0)$ for some $A_j \in X_{\mathbf{R}}$. For $x \in X$, we set

$$x_N = x + N(c_1 - c_0) + N(c_2 - c_0) + \dots + N(c_q - c_0).$$

If N is large enough, then

$$F_j(x_N + c_0) = (A_j, x_N) = (A_j, x) + N \cdot (F_j(c_1) + \dots + F_j(c_q)) > 0$$

This implies that $x_N + c_0 \in C(c_0, \text{Star}(\mathbf{c}))^0$. It suffices to choose $x' = x_N$ for (i).

Next we prove (ii). Suppose $x' + c_0 \in C(c_0, \text{Star}(\mathbf{c}))^0$ and $x' \equiv x \pmod{X(\mathbf{c})}$. Since $\text{Star}(\mathbf{c})$ is the union of all the Delaunay cells σ with $|\mathbf{c}| \subset \sigma$ and since Del is a polyhedral decomposition of $X_{\mathbf{R}}$, there is the *minimal* Delaunay cell σ such that $|\mathbf{c}| \subset \sigma$ and $x' + c_0 \in C(c_0, \sigma)$. If $x' + c_0 \notin C(c_0, \sigma)^0$, then $x' + c_0 \in C(c_0, \tau)$ for a face τ of σ . Since $x' + c_0 \in C(c_0, \text{Star}(\mathbf{c}))^0$, τ intersects $\text{Star}(\mathbf{c})^0$, hence the relative interior τ^0 of τ intersects the interior of $\text{Star}(\mathbf{c})$. Hence $\tau \subset \text{Star}(\mathbf{c})$, whence $|\mathbf{c}| \subset \tau$. This contradicts that σ is minimal. This proves (ii).

Finally we prove (iii). Suppose $x' + c_0 \in C(c_0, \sigma')^0$ and $x'' + c_0 \in C(c_0, \sigma'')^0$ and that $x' \equiv x'' \equiv x \pmod{X(\mathbf{c})}$. Then $x' = x'' + \sum_{j=1}^q a_j(c_j - c_0)$ for some $a_j \in \mathbf{Z}$. Since $x' + c_0 + \sum_{j=1}^q N'_j(c_j - c_0)$ (resp. $x'' + c_0 + \sum_{j=1}^q N''_j(c_j - c_0)$) stays inside $C(c_0, \sigma')^0$ (resp. $C(c_0, \sigma'')^0$) for any large $N'_j > 0$ and $N''_j > 0$, $C(c_0, \sigma')^0$ and $C(c_0, \sigma'')^0$, two cones at c_0 of Delaunay cells, have common relative interior points. It follows $C(c_0, \sigma') = C(c_0, \sigma'')$ and $\dim \sigma' = \dim \sigma''$. Since $c_0 \in \sigma' \subset C(c_0, \sigma')$, $c_0 \in \sigma'' \subset C(c_0, \sigma'')$, two Delaunay cells σ' and σ'' have common relative interiors. Therefore $\sigma' = \sigma''$. It is clear that σ' depends only on the class $(x \pmod{X(\mathbf{c})})$, and is independent of the choice of $x \in X$. Q.E.D.

Definition 5.7. Let $\mathbf{c} = (c_0, \dots, c_q)$ with $c_j \in X$ cellmates. We recall $|\mathbf{c}| = \{c_0, \dots, c_q\}$. We define $\text{Del}(\mathbf{c})$ to be $\text{Del}(|\mathbf{c}|)$. Let $\text{Del}^{(g-k)}(\mathbf{c}) = \text{Del}(\mathbf{c}) \cap \text{Del}^{(g-k)}$. We define $C(\mathbf{c}, \sigma) := C(|\mathbf{c}|, \sigma)$, which is the union of all the translates $C(c_0, \sigma)$ by $a \in X(\mathbf{c})$. See Definition 2.2. This depends only on the unordered set \mathbf{c} , independent of the order of c_j .

Lemma 5.8. *Let c_0, c_1, \dots, c_q be cellmates, $\mathbf{c} = (c_0, \dots, c_q)$ ordered cellmates, and $|\mathbf{c}|$ unordered cellmates. Let*

$$R(\mathbf{c}) := \bigoplus_{x \in X} k(0) \cdot \xi(x, \mathbf{c})$$

for some nonzero monomials $\xi(x, \mathbf{c})$. Then

(i) *If there is some $\sigma \in \text{Del}(\mathbf{c})$ such that $x \in C(0, \sigma - c_0) \cap X$, then*

$$\xi(x, \mathbf{c}) = \xi(x, c_0).$$

(ii) *If there are $a \in X(\mathbf{c})$ and $\sigma \in \text{Del}(\mathbf{c})$ such that $x - a \in C(0, \sigma - c_0) \cap X$,*

$$\xi(x, \mathbf{c}) = q^{(a, \alpha(\sigma))} w^a \cdot \xi(x - a, c_0).$$

(iii)

$$R(\mathbf{c}) = \bigoplus_{\substack{\sigma \in \text{Del}(\mathbf{c}), x \in X/X(\mathbf{c}) \\ x + c_0 \in C(\mathbf{c}, \sigma) \cap X}} k(0)[X(\mathbf{c})] \cdot \xi(x, c_0)$$

Proof. Suppose that some $\sigma \in \text{Del}(\mathbf{c})$ such that $x \in C(0, \sigma - c_0) \cap X$. The element $\xi(x, \mathbf{c})$ is nonzero on $U(\mathbf{c})$, hence it is nonzero on $U(c_0)$ because $U(\mathbf{c}) \subset U(c_0)$. Thus it restricts to a nonzero element of $R(c_0)$ of weight x , which is $\xi(x, c_0)$. Hence $\xi(x, \mathbf{c}) = \xi(x, c_0)$. This proves (i).

Next we prove (ii). We choose $\tau \in \text{Del}$ such that $|\mathbf{c}| \subset \tau$. It is clear that

$$R(\mathbf{c}) := \bigoplus_{x \in X} k(0) \cdot \xi(x, \mathbf{c}) = \bigoplus_{x \in X/X(\mathbf{c})} k(0)[X(\mathbf{c})] \cdot \xi(x, \mathbf{c})$$

for some nonzero element $\xi(x, \mathbf{c})$ of weight $x \in X$. Suppose that $a \in X(\mathbf{c})$, $\sigma \in \text{Del}(\mathbf{c})$ and $x - a \in C(0, \sigma - c_0) \cap X$. Let $\zeta = q^{(a, \alpha(\sigma))} w^a \in k(0)[X(\mathbf{c})]$. Since ζ is a unit in $k(0)[X(\mathbf{c})]$ by Lemma 5.5, we have $\xi(x, \mathbf{c}) = \xi(x - a, \mathbf{c})\zeta$ for any $x \in X$. It is equal to $\xi(x - a, c_0)\zeta = \xi(x - a, c_0)q^{(a, \alpha(\sigma))} w^a$ by (i). This proves (ii).

Next we prove (iii). We choose $\tau \in \text{Del}(\mathbf{c})$. We choose and fix any $x \in X$ and let $\bar{x} \in X/X(\mathbf{c})$ be the class of x . We define

$$R(\mathbf{c})_{\bar{x}} := \bigoplus_{z \in x + X(\mathbf{c})} k(0) \cdot \xi(z, \mathbf{c}) = k(0)[X(\mathbf{c})] \cdot \xi(x, \mathbf{c}).$$

If necessary, by multiplying $\xi(x, \mathbf{c})$ by a product of ξ_{c_j}/ξ_{c_0} , which is of the form $q^{(a, \alpha(\tau))} w^a$ for some $a \in X(\mathbf{c})$, we can choose $\xi(x, \mathbf{c}) \cdot q^{(a, \alpha(\tau))} w^a \in R(c_0)$ as a generator of $k(0)[X(\mathbf{c})]$ -module $k(0)[X(\mathbf{c})]\xi(x, \mathbf{c})$.

Hence we may assume $\xi(x, \mathbf{c}) \in R(c_0)$ from the start. The element $\xi(x, \mathbf{c})$ is nonzero on $U(\mathbf{c})$, hence $\xi(x, \mathbf{c}) = \xi(x, c_0)$ by (i). Next for N large enough we choose x_N instead of x with the notation of Lemma 5.6. Then by Lemma 5.6 there is $\sigma \in \text{Del}$ such that $x_N \in C(0, \sigma - c_0)^0 \cap X$, $|\mathbf{c}| \subset \sigma$ and

$$R(\mathbf{c})_{\bar{x}} = k(0)[X(\mathbf{c})] \cdot \xi(x, c_0) = k(0)[X(\mathbf{c})] \cdot \xi(x_N, c_0)$$

where

$$\xi(x_N, c_0) = \xi(x, c_0) \cdot \prod_{j=1}^q \left(\frac{\xi_{c_j}}{\xi_{c_0}} \right)^N.$$

Hence $x + c_0 = x_N + c_0 - N \sum_{j=1}^q (c_j - c_0) \in C(\mathbf{c}, \sigma) \cap X$. This proves (iii). Q.E.D.

Definition 5.9. Let $\mathbf{c} = (c_0, \dots, c_q)$ with $c_j \in X$ cellmates. We define $\ell(\mathbf{c}) = q$. For a Delaunay cell $\sigma \in \text{Del}^{(g-k)}(\mathbf{c})$, we define

$$F_{\sigma}^{k,q}(\mathbf{c}) = \bigoplus_{\substack{x + c_0 \in C(\mathbf{c}, \sigma) \cap X \\ \ell(\mathbf{c}) = q}} k(0) \cdot \xi(x, \mathbf{c}),$$

$$F^{k,q}(\mathbf{c}) = \bigoplus_{\substack{|\mathbf{c}| \subset \sigma \in \text{Del}^{(g-k)} \\ \ell(\mathbf{c}) = q}} F_{\sigma}^{k,q}(\mathbf{c}) = \bigoplus_{\substack{\sigma \in \text{Del}^{(g-k)}(\mathbf{c}) \\ \ell(\mathbf{c}) = q}} F_{\sigma}^{k,q}(\mathbf{c}),$$

$$F^{k,q} = \bigoplus_{\substack{\mathbf{c} : \text{cellmates} \\ \ell(\mathbf{c}) = q}} F^{k,q}(\mathbf{c}) = \bigoplus_{\substack{\mathbf{c} : \text{cellmates} \\ \ell(\mathbf{c}) = q}} \left(\bigoplus_{\sigma \in \text{Del}^{(g-k)}(\mathbf{c})} F_{\sigma}^{k,q}(\mathbf{c}) \right).$$

where $F^{k,0}(c) = F^k(c)$ for $c \in X$.

The definition of $F_{\sigma}^{k,q}(\mathbf{c})$ is independent of the choice of $c_0 \in |\mathbf{c}|$. We note that if $\mathbf{c} = (c_0, c_1, \dots, c_q)$ are not cellmates or if $\mathbf{c} = (c_0, c_1, \dots, c_q)$ are cellmates but $|\mathbf{c}| \not\subset \sigma$, then $F_{\sigma}^{k,q}(\mathbf{c}) = 0$. For $\sigma \in \text{Del}^{(g-k)}$ we also define

$$F_{\sigma}^k = \bigoplus_{q=0}^{\infty} F_{\sigma}^{k,q}, \quad F_{\sigma}^{k,q} = \bigoplus_{|\mathbf{c}| \subset \sigma, \ell(\mathbf{c}) = q} F_{\sigma}^{k,q}(\mathbf{c})$$

Finally we define $\partial^{k,q} : F^{k,q}(\mathbf{c}) \rightarrow F^{k+1,q}(\mathbf{c})$ by

$$\partial^{k,q} \left(\bigoplus_{\sigma \in \text{Del}^{(g-k)}(\mathbf{c})} \phi_{\sigma} \right) = \bigoplus_{\tau \in \text{Del}^{(g-k-1)}(\mathbf{c})} \sum_{|\mathbf{c}| \subset \tau \subset \sigma} [\sigma : \tau] \text{res}_{\tau}^{\sigma}(\phi_{\sigma})$$

where $\phi_\sigma \in F_\sigma^{k,q}(\mathbf{c})$, and the summation in RHS ranges over the set of all σ containing a fixed τ as a face of codimension one. We note $\partial^{k+1,q} \cdot \partial^{k,q} = 0$.

Lemma 5.10. *Suppose $q \geq 1$ and that c_0, \dots, c_{q-1}, c_q are cellmates. Let $\mathbf{c}' = (c_0, \dots, c_{q-1})$, $\mathbf{c} = (c_0, \dots, c_q)$ and $\sigma \in \text{Del}^{(g-k)}(\mathbf{c})$. Let*

$$F_\sigma^{k,q-1}(\mathbf{c}') = \bigoplus_{x+c_0 \in C(\mathbf{c}', \sigma) \cap X} k(0) \cdot \xi(x, \mathbf{c}')$$

$$F_\sigma^{k,q}(\mathbf{c}) = \bigoplus_{x+c_0 \in C(\mathbf{c}, \sigma) \cap X} k(0) \cdot \xi(x, \mathbf{c}).$$

Then $\xi(x, \mathbf{c}') = \xi(x, \mathbf{c})$.

Proof. It is clear from $\sigma \in \text{Del}(\mathbf{c})$ that $\sigma \in \text{Del}(\mathbf{c}')$. If $x \in C(0, \sigma - c_0) \cap X$, then $\xi(x, \mathbf{c}') = \xi(x, \mathbf{c}) = \xi(x, c_0)$ by Lemma 5.8. Otherwise we choose $a \in X(\mathbf{c}')$ such that $x - a \in C(0, \sigma - c_0) \cap X$. Then $\xi(x - a, \mathbf{c}') = \xi(x - a, \mathbf{c}) = \xi(x - a, c_0)$. Let $\zeta = q^{(a, \alpha(\sigma))} w^a$ for the hole $\alpha(\sigma) \in \sigma$. Since ζ is a unit in both $R(\mathbf{c}')$ and $R(\mathbf{c})$, by the definition of generators $\xi(x, \mathbf{c}')$ and $\xi(x, \mathbf{c})$ we have $\xi(x, \mathbf{c}') = \xi(x - a, \mathbf{c}')\zeta$ and $\xi(x, \mathbf{c}) = \xi(x - a, \mathbf{c})\zeta$. It follows $\xi(x, \mathbf{c}') = \xi(x, \mathbf{c})$. Q.E.D.

Lemma 5.11. *Let $\mathbf{c} = (c_0, \dots, c_q)$ be cellmates with $\ell(\mathbf{c}) = q$. Then the following sequence of $k(0)[X(\mathbf{c})]$ -modules is exact,*

$$0 \rightarrow R(\mathbf{c}) \rightarrow F^{0,q}(\mathbf{c}) \xrightarrow{\partial^{0,q}} F^{1,q}(\mathbf{c}) \rightarrow \dots \rightarrow F^{g-1,q}(\mathbf{c}) \xrightarrow{\partial^{g-1,q}} F^{g,q}(\mathbf{c}) \rightarrow 0.$$

Proof. The proof is similar to that of Lemma 5.2. Imitating the proof of Lemma 5.2, for each class $\bar{x} \in X/X(\mathbf{c})$, we choose by Lemma 5.2 a Delaunay cell $\sigma_{\min}(x, \mathbf{c}) \in \text{Del}(\mathbf{c})$ such that $x + c_0 \in C(c_0, \sigma_{\min}(x, \mathbf{c}))^0$ and $x \in \bar{x} + X(\mathbf{c})$, which is uniquely determined by \bar{x} . In what follows, for each \bar{x} we choose and fix the pair $(x, \sigma_{\min}(x, \mathbf{c}))$ such that $x + c_0 \in C(c_0, \sigma_{\min}(x, \mathbf{c}))^0$ and $x \in \bar{x} + X(\mathbf{c})$. Let $g - k = \dim \sigma_{\min}(x, \mathbf{c})$. We note $\sigma \in \text{Del}(\mathbf{c})$ iff $\sigma_{\min}(x, \mathbf{c}) \subset \sigma$. For any $\sigma \in \text{Del}(\mathbf{c})$, we have $x \in C(0, \sigma - c_0)$ because $x \in C(0, \sigma_{\min}(x, \mathbf{c}) - c_0)$. In what follow, for any $\sigma \in \text{Del}(\mathbf{c})$ we choose the same $\xi(x, c_0)$ as a common generator of $k(0)[X(\mathbf{c})]$ -modules $F_\sigma^k(\mathbf{c})_x$ and $R(\mathbf{c})$.

For a fixed $x \in X$ (or a fixed class $x \in X/X(\mathbf{c})$) we define

$$F_\sigma^k(\mathbf{c})_x := \begin{cases} k(0)[X(\mathbf{c})] \cdot \xi(x, c_0) & \text{if } x \in C(0, \sigma - c_0) \cap X \\ 0 & \text{(otherwise)} \end{cases}$$

and

$$F^{k,q}(\mathbf{c})_x := \bigoplus_{\substack{\sigma \in \text{Del}^{(g-k)}(\mathbf{c}) \\ x + c_0 \in C(\mathbf{c}, \sigma) \cap X}} F^k(\mathbf{c})_x.$$

We also denote $R(\mathbf{c})_{\bar{x}}$ by $R(\mathbf{c})_x$. We define $\partial^{k,q} : F^{k,q}(\mathbf{c})_x \rightarrow F^{k+1,q}(\mathbf{c})_x$ by restriction of $\partial^{k,q}$ in Definition 5.9. Thus we have a complex of $k(0)[X(\mathbf{c})]$ -modules with coboundary operators $\partial^{k,q}$

$$F^{0,q}(\mathbf{c})_x \xrightarrow{\partial^{0,q}} F^{1,q}(\mathbf{c})_x \xrightarrow{\partial^{1,q}} \dots \xrightarrow{\partial^{g-2,q}} F^{g-1,q}(\mathbf{c})_x \xrightarrow{\partial^{g-1,q}} F^{g,q}(\mathbf{c})_x \rightarrow 0.$$

The exactness of the sequence as well as $R(\mathbf{c}) \simeq \text{Ker}(\partial^{0,q})$ is proved in a manner entirely analogous to Lemma 5.2. Q.E.D.

Definition 5.12. Let θ_{cd} be the one cocycle associated with L_0 :

$$\theta_{cd} = \xi_d / \xi_c$$

In order to compute $H^q(Q_0, L_0^n)$ we define a complex ${}_nR$ by

$${}_nR^q = \bigoplus_{\ell(\mathbf{c})=q} R(\mathbf{c})$$

where $f(c_0, \dots, c_q) \in R(\mathbf{c})$ and $g(d_0, \dots, d_q) \in R(\mathbf{d})$ are identified iff

$$|\mathbf{c}| = |\mathbf{d}|, \quad \xi_{c_0}^n f(c_0, \dots, c_q) = \xi_{d_0}^n g(d_0, \dots, d_q).$$

We define the twisted coboundary operator $\delta_n^q : {}_nR^q \rightarrow {}_nR^{q+1}$ by

$$\begin{aligned} \xi_{c_0}^n g(c_0, c_1, \dots, c_{q+1}) &= \xi_{c_1}^n f(c_1, c_2, \dots, c_{q+1}) \\ &\quad + \sum_{j=1}^{q+1} (-1)^j \xi_{c_0}^n f(c_0, \dots, \hat{c}_j, \dots, c_{q+1}). \end{aligned}$$

where $f = \sum f(c_0, c_1, \dots, c_q) \in {}_nR^q$, $g = \delta_n^q f \in {}_nR^{q+1}$.

Definition 5.13. Now we define ${}_nF^{k,q}$ and the twisted coboundary operator $\delta_n^{k,q} : {}_nF^{k,q} \rightarrow {}_nF^{k,q+1}$ so that the definitions of $\delta_n^{k,q}$ for ${}_nR^q$ and ${}_nF^{k,q}$ are compatible. Let $\mathbf{c} = (c_0, \dots, c_q)$ be ordered cellmates, ${}_nF^{k,q}(\mathbf{c}) = F^{k,q}(\mathbf{c})$. We define

$${}_nF^{k,q} = \bigoplus_{\ell(\mathbf{c})=q} {}_nF^{k,q}(\mathbf{c})$$

where $f(c_0, \dots, c_q) \in {}_nF^{k,q}(\mathbf{c})$ and $g(d_0, \dots, d_q) \in {}_nF^{k,q}(\mathbf{d})$ are identified iff

$$|\mathbf{c}| = |\mathbf{d}|, \quad \xi_{c_0}^n f(c_0, \dots, c_q) = \xi_{d_0}^n g(d_0, \dots, d_q).$$

For $f \in {}_n F^{k,q}$, we define $\delta_n^{k,q} : {}_n F^{k,q} \rightarrow {}_n F^{k,q+1}$ as follows.
 Let $f = \bigoplus f(c_0, c_1, \dots, c_q) \in {}_n F^{k,q}$ and $g = \delta_n^{k,q} f \in {}_n F^{k,q+1}$. Then

$$\begin{aligned} \xi_{c_0}^n g(c_0, c_1, \dots, c_{q+1}) &= \xi_{c_1}^n f(c_1, c_2, \dots, c_{q+1}) \\ &\quad + \sum_{j=1}^{q+1} (-1)^j \xi_{c_0}^n f(c_0, \dots, \hat{c}_j, \dots, c_{q+1}). \end{aligned}$$

If $\mathbf{c} = (c_0, c_1, \dots, c_q)$ are not cellmates, then we have ${}_n F^{k,q}(\mathbf{c}) = 0$ and $f(c_0, c_1, \dots, c_q) = 0$ by definition. We note $\delta_n^{k,q} \cdot \delta_n^{k,q-1} = 0$. Since we have $\delta_n^{k,q}({}_n F_\sigma^{k,q}) \subset {}_n F_\sigma^{k,q+1}$, we have a complex

$${}_n F_\sigma^{k,0} \xrightarrow{\delta_n^{k,0}} {}_n F_\sigma^{k,1} \xrightarrow{\delta_n^{k,1}} \dots \xrightarrow{\delta_n^{k,q-1}} {}_n F_\sigma^{k,q} \xrightarrow{\delta_n^{k,q}} {}_n F_\sigma^{k,q+1} \rightarrow \dots$$

Definition 5.14. For each positive integer n , we define a double complex $({}_n C^\cdot, \Delta_n^\cdot)$ by

$$\begin{aligned} {}_n C^\cdot &= \bigoplus {}_n C^p, \quad {}_n C^p = \bigoplus_{k+q=p} {}_n F^{k,q}, \quad \Delta_n^p = \bigoplus_{k+q=p} (\partial^{k,q} + (-1)^q \delta_n^{k,q}), \\ {}_n F^{k,q} &= \bigoplus_{\sigma \in \text{Del}^{(g-k)} \bmod Y} {}_n F_\sigma^{k,q} = \bigoplus_{\sigma \in \text{Del}^{(g-k)} \bmod Y} \left(\bigoplus_{x \in X} {}_n F_\sigma^{k,q}[x] \right), \\ {}_n F_\sigma^{k,q}[x] &= \bigoplus_{\substack{|\mathbf{c}| \subset \sigma \\ \ell(\mathbf{c}) = q}} {}_n F_\sigma^{k,q}(\mathbf{c})[x] \end{aligned}$$

where ${}_n F_\sigma^{k,q}[x]$ is the weight x -part of ${}_n F_\sigma^{k,q}$, and $\partial^{k,q}$ on ${}_n F_\sigma^{k,q}$ is defined to be $\partial^{k,q}$ on $F_\sigma^{k,q}$. We easily check

$$\begin{aligned} \Delta_n^{p+1} \cdot \Delta_n^p &= 0, \\ \partial^{k+1,q} \cdot \partial^{k,q} &= 0, \quad \delta_n^{k,q+1} \cdot \delta_n^{k,q} = 0, \\ \delta_n^{k+1,q} \cdot \partial^{k,q} &= \partial^{k,q+1} \cdot \delta_n^{k,q}, \\ \partial^{k,q}({}_n F^{k,q}) &\subset {}_n F^{k+1,q}, \quad \delta_n^{k,q}({}_n F^{k,q}) \subset {}_n F^{k,q+1}. \end{aligned}$$

We also check that $\delta_n^{k+1,q} \cdot \text{res}_\tau^\sigma = \text{res}_\tau^\sigma \cdot \delta_n^{k,q}$.

The following theorem will be proved in the section 6.

Theorem 5.15. For any $\sigma \in \text{Del}^{(g-k)}$, there is a natural isomorphism

$$\mathbf{H}^q({}_n F_\sigma^{k,\cdot}, \delta_n^{k,\cdot}) = \begin{cases} \bigoplus_{\frac{\mathbb{Z}}{n} \in \sigma \cap \frac{\mathbb{Z}}{n} \bmod Y} k(0) \cdot [x] & \text{if } q = 0 \\ 0 & \text{if } q > 0 \end{cases}$$

where $[x]$ denotes the monomial generator $\xi_c^n \xi(x - nc, c)$ of weight x , which is independent of the choice of $c \in \sigma \cap X$.

Remark 5.16. When Q_0 is reduced, the cohomology group in Theorem 5.15 coincides with $H^q(V(\sigma), L_0^n \otimes O_{V(\sigma)})$. However there might be no subscheme of Q_0 which properly corresponds to σ when Q_0 is nonreduced.

Theorem 5.17. Let (Q_0, L_0) be a PSQAS with a level $G(K)$ -structure, the closed fibre of (Q, L) . Then

- (i) $H^q(Q_0, L_0^n) = 0$ for $q \geq 1$ and $n \geq 1$.
- (ii) $\dim H^0(Q_0, L_0^n) = n^g \sqrt{|K|}$ for $n \geq 1$.

Proof. We note that the assertion (i) is always true for any PSQASes.

We prove (i). First we consider the case where (Q_0, L_0) is totally degenerate, in which case $\sqrt{|K|} = |X/Y|$ by [Nr99, Lemma 5.12, Lemma 7.11]. We use the complex $({}_n C^\cdot, \Delta_n)$ to prove $H^q(Q_0, L_0^n) = 0$.

First we compute the spectral sequences for the above complex. By Theorem 5.15

$${}'E_1^{k,q} = \begin{cases} \bigoplus_{\sigma \in \text{Del}^{(g-k)} \bmod Y} \left(\bigoplus_{\frac{x}{n} \in \sigma \cap \frac{X}{n}} k(0) \cdot [x] \right) & \text{if } q = 0 \\ 0 & \text{if } q > 0. \end{cases}$$

It follows ${}'E_2^{k,q} = 0$ for $q > 0$.

In view of Lemma 5.2 and Lemma 5.11

$${}''E_1^{k,q} = \begin{cases} {}_n R^q & \text{if } k = 0 \\ 0 & \text{if } k > 0 \end{cases}$$

Therefore we have

$$\begin{aligned} {}''E_2^{k,q} &= \begin{cases} H^q({}_n R^\cdot, \delta_n^\cdot) & \text{if } k = 0 \\ 0 & \text{if } k > 0 \end{cases} \\ &= \begin{cases} H^q(Q_0, L_0^n) & \text{if } k = 0 \\ 0 & \text{if } k > 0 \end{cases} \end{aligned}$$

because $U(\mathbf{c})$ is affine for any cellmates \mathbf{c} .

Since the spectral sequences degenerate at E_2 -terms, we see

$$H^q(Q_0, L_0^n) = {}''E_2^{0,q} = \mathbf{H}^q({}_n C^\cdot, \Delta_n) = {}'E_2^{q,0}.$$

Since the coboundary operator of the complex $({}'E_1^{\cdot,0}, \delta_n^{\cdot,0})$ is (regarded as) homogeneous (see the proof of Theorem 6.11), it suffices to

compute the weight x -part of the cohomology $'E_2^{q,0}[x]$ of the complex. Let $\text{Star}(\frac{x}{n})$ be the union of $\sigma \in \text{Del}$ such that $\frac{x}{n} \in \sigma$ and $\text{Star}(\frac{x}{n})^0$ the relative interior of $\text{Star}(\frac{x}{n})$. We see $H^0(\text{Star}(\frac{x}{n})^0, k(0)) = k(0)$ and $H^q(\text{Star}(\frac{x}{n})^0, k(0)) = 0$ for $q > 0$. It is also easy to see that the weight x -part of the complex $(E_1^{\cdot,0}, \delta_n^{\cdot,0})$ is isomorphic to the cochain complex of $\text{Star}(\frac{x}{n})^0$ indexed by Delaunay cells. Hence for $q > 0$

$$'E_2^{q,0}[x] = H^q(\text{Star}(\frac{x}{n})^0, k(0)) = 0 \quad (\forall x),$$

$$H^q(Q_0, L_0^n) = ''E_2^{0,q} = 'E_2^{q,0} = \bigoplus_{\frac{x}{n} \in \frac{X}{n} \bmod Y} 'E_2^{q,0}[x] = 0.$$

Since Q is flat over R , we have $\dim H^0(Q_0, L_0^n) = \dim H^0(Q_\eta, L_\eta^n) = n^g |X/Y|$ where (Q_η, L_η^n) is the generic fibre of (Q, L^n) . This completes the proof in the totally-degenerate case when $Y \subset mX$ for some $m \geq 3$.

Next we consider the case where Y is not a subgroup of mX for any $m \geq 3$. We note that (Q_0, L_0) has an étale covering $(Q'_0, L'_0) = (\tilde{Q}_0, \tilde{L}_0)/Y'$ where we choose $Y' = 3Y$. The second PSQAS (Q'_0, L'_0) satisfies the assumption $Y' = 3Y \subset 3X$, from which we infer that $\dim H^q(Q'_0, (L'_0)^n) = 0$ for any $q > 0$. Since $H^q(Q_0, L_0^n)$ is a direct summand of $H^q(Q'_0, (L'_0)^n) = 0$, we have $H^q(Q_0, L_0^n) = 0$ for $q > 0$. Once we prove $H^q(Q_0, L_0^n) = 0$ for $q > 0$, then since Q is flat over R , we have $\dim H^0(Q_0, L_0^n) = \dim H^0(Q_\eta, L_\eta^n) = n^g |X/Y| = n^g \sqrt{|K|}$. Thus we complete the proof of the theorem in the totally degenerate case. The vanishing in the partially degenerate case follows easily from it by the standard argument. See [Nr99, Theorem 4.10]. Q.E.D.

The following is a corollary to Theorem 5.17.

Theorem 5.18. *Let $k(0)$ be a field of characteristic prime to $|K|$, and (Q_0, L_0) be a PSQAS over $k(0)$ with a level $G(K)$ -structure. Then*

- (i) $\dim H^0(Q_0, L_0) = \sqrt{|K|}$
- (ii) $H^0(Q_0, L_0)$ is an irreducible $G(K)$ -module of weight one.

Proof. Since $H^q(Q_0, L_0) = 0$ for $q > 0$ by Theorem 5.17, we see $H^0(Q_0, L_0) = \Gamma(Q, L) \otimes k(0)$. Therefore $\Gamma(Q, L) \otimes k(0)$ is an irreducible $G(K)$ -module of weight one in view of [Nr99, Lemma 5.12]. This proves the theorem. Q.E.D.

Corollary 5.19. *Let K be a finite symplectic abelian group and $\pi : (Q, L) \rightarrow SQ_{g,K}$ the universal family of PSQASes over $SQ_{g,K}$. Then $\pi_*(L^n)$ is locally free for any $n > 0$.*

Proof. Since $SQ_{g,K}$ is reduced by the definition of [Nr99, § 12], $\pi_*(L^n)$ is locally free by Theorem 5.17 and [M74, Corollary 2, p. 51].
Q.E.D.

§6. Proof of Theorem 5.15

Lemma 6.1. *Let $\sigma \in \text{Del}^{(g)}$ and $\mathbf{c} = (c_0, \dots, c_q)$ cellmates such that $|\mathbf{c}| \subset \sigma$. Suppose $0 \in |\mathbf{c}|$. Let f_j ($1 \leq j \leq N$) be linear functions on $X_{\mathbf{R}}$ such that $C(0, \sigma) = \{x \in X_{\mathbf{R}}; f_j(x) \geq 0 \ (1 \leq j \leq N)\}$, $f_j(c_k) = 0$ ($\forall j \leq n, \forall k$) and $f_j(c_{k_j}) > 0$ ($\forall j > n, \exists k_j$). Then we have*

$$C(\mathbf{c}, \sigma) = \{x \in X_{\mathbf{R}}; f_j(x) \geq 0 \ (\forall j \leq n)\}.$$

Proof. First we note that f_j ($1 \leq j \leq n$) is the set of all f_j whose restriction to $|\mathbf{c}|$ is identically zero. Let $S = \{x \in X_{\mathbf{R}}; f_j(x) \geq 0 \ (\forall j \leq n)\}$. Let $a \in X(\mathbf{c})_{\mathbf{R}}$ and $x \in C(0, \sigma)$. Then since f_j is linear, $f_j(x+a) = f_j(x) + f_j(a) = f_j(x) \geq 0$ for $j \leq n$. Therefore $C(\mathbf{c}, \sigma) \subset S$. We shall prove the converse. Let $\langle \mathbf{c} \rangle$ be the convex closure of $|\mathbf{c}|$. By the choice of f_k ($1 \leq k \leq N$) there is an $a \in \langle \mathbf{c} \rangle$ such that $f_j(a) > 0$ for any $j \geq n+1$. Hence if $x \in S$, then $f_j(x+Aa) = f_j(x) + Af_j(a) > 0$ for a large $A > 0$. Hence $x+Aa \in C(0, \sigma)$. Since $Aa = A(a-0)$, $a \in \langle \mathbf{c} \rangle$ and $0 \in |\mathbf{c}|$, we see $Aa \in X(\mathbf{c})_{\mathbf{R}}$. This proves $x \in X(\mathbf{c})_{\mathbf{R}} + C(0, \sigma) = C(\mathbf{c}, \sigma)$. Q.E.D.

Lemma 6.2. *Let $\sigma \in \text{Del}^{(g)}$, $\mathbf{c} = (c_0, \dots, c_q)$ cellmates such that $|\mathbf{c}| \subset \sigma$, and $\tau(\mathbf{c})$ the minimal Delaunay cell containing $|\mathbf{c}|$. Then $C(\mathbf{c}, \sigma) = C(\tau(\mathbf{c}), \sigma)$.*

Proof. It should be cautioned that $X(\mathbf{c}) \neq X(\tau(\mathbf{c}))$ in general. We may assume $c_0 = 0$ without loss of generality. Then by Lemma 6.1 $C(\mathbf{c}, \sigma) = \{x \in X_{\mathbf{R}}; f_j(x) \geq 0 \ (\forall j \leq n)\}$. Let H be a hyperplane of $X_{\mathbf{R}}$ defined by $f_j = 0$ for some j ($1 \leq j \leq n$). Then $H \cap \sigma$ is a face of σ . Since $|\mathbf{c}| \subset H \cap \sigma$, $\tau(\mathbf{c}) \subset H \cap \sigma$ by the definition of $\tau(\mathbf{c})$. Hence $f_j = 0$ on $\tau(\mathbf{c})$, hence $f_j = 0$ on $X(\tau(\mathbf{c}))$. It follows that $X(\tau(\mathbf{c})) \subset C(\mathbf{c}, \sigma)$. This proves the lemma. Q.E.D.

Lemma 6.3. *Let $\sigma \in \text{Del}^{(g)}$ and τ and τ' faces of σ with $\tau \cap \tau' \neq \emptyset$. Then $C(\tau, \sigma) \cap C(\tau', \sigma) = C(\tau \cap \tau', \sigma)$.*

Proof. We may assume $0 \in \tau \cap \tau'$ without loss of generality. It suffices to prove $C(\tau, \sigma) \cap C(\tau', \sigma) \subset C(\tau \cap \tau', \sigma)$. By the proof of Lemma 6.1 we have linear functions f_j ($1 \leq j \leq N$) such that

$$\begin{aligned} C(0, \sigma) &= \{x \in X_{\mathbf{R}}; f_j(x) \geq 0 \ (1 \leq j \leq N)\}, \\ C(0, \tau) &= \{x \in C(0, \sigma); f_j(x) = 0 \ (1 \leq j \leq n)\}, \\ C(0, \tau') &= \{x \in C(0, \sigma); f_j(x) = 0 \ (1 \leq j \leq k \text{ and } n+1 \leq j \leq m)\}. \end{aligned}$$

It follows $C(0, \tau \cap \tau') = \{x \in C(0, \sigma); f_j(x) = 0 (\forall j \leq m)\}$. Hence

$$C(\tau \cap \tau', \sigma) = \{x \in X_{\mathbf{R}}; f_j(x) \geq 0 (\forall j \leq m)\}.$$

By Lemma 6.1 we see

$$\begin{aligned} C(\tau, \sigma) &= \{x \in X_{\mathbf{R}}; f_j(x) \geq 0 (1 \leq j \leq n)\}, \\ C(\tau', \sigma) &= \{x \in X_{\mathbf{R}}; f_j(x) \geq 0 (1 \leq j \leq k \text{ and } n + 1 \leq j \leq m)\}. \end{aligned}$$

It follows that

$$C(\tau, \sigma) \cap C(\tau', \sigma) = \{x \in X_{\mathbf{R}}; f_j(x) \geq 0 (1 \leq j \leq m)\}.$$

This completes the proof.

Q.E.D.

Example 6.4. Let $g = 2$ and $B(x, x) = x_1^2 + x_2^2$ for $x = x_1e_1 + x_2e_2 \in X$. Let $\sigma = \langle 0, e_1, e_1 + e_2, e_2 \rangle$, $\tau = \{0\}$ and $\tau' = \{e_1 + e_2\}$. In this case,

$$\begin{aligned} C(\tau, \sigma) &= \{x_1e_1 + x_2e_2; x_1, x_2 \geq 0\}, \\ C(\tau', \sigma) &= \{x_1e_1 + x_2e_2; x_1, x_2 \leq 1\}. \end{aligned}$$

Hence $C(\tau, \sigma) \cap C(\tau', \sigma) = \sigma \neq \emptyset$, while $\tau \cap \tau' = \emptyset$.

Next let $\rho = \langle 0, e_1 \rangle$ and $\rho' = \langle e_2, e_1 + e_2 \rangle$. We note $\rho \cap \rho' = \emptyset$. Then

$$\begin{aligned} C(\rho, \sigma) &= \{x_1e_1 + x_2e_2; x_2 \geq 0\}, \quad C(\rho', \sigma) = \{x_1e_1 + x_2e_2; x_2 \leq 1\}, \\ C(\rho, \sigma) \cap C(\rho', \sigma) &= \{x_1e_1 + x_2e_2; 0 \leq x_2 \leq 1\}. \end{aligned}$$

Thus Lemma 6.3 is true only when $\tau \cap \tau'$ is nonempty.

Definition 6.5. We choose and fix $\sigma \in \text{Del}^{(g)}$. For each $\rho \in \text{Del}_{\sigma}^{(g-1)}$, $C(\rho, \sigma)$ is a closed half-space of $X_{\mathbf{R}}$. Let $C(\rho, \sigma)^c$ be the complement of $C(\rho, \sigma)$ in $X_{\mathbf{R}}$. Let $\mathcal{H} := \mathcal{H}(\sigma)$ be the set of all hyperplanes of $X_{\mathbf{R}}$ of the form $H(\rho) := \rho + X(\rho)_{\mathbf{R}}$ for some $\rho \in \text{Del}_{\sigma}^{(g-1)}$. For any subset \mathcal{H}' of $\mathcal{H}(\sigma)$ we define

$$D(\mathcal{H}') = \left(\bigcap_{H(\rho) \in \mathcal{H} \setminus \mathcal{H}'} C(\rho, \sigma) \right) \cap \left(\bigcap_{H(\rho) \in \mathcal{H}'} C(\rho, \sigma)^c \right).$$

We note that the expression in RHS could be redundant because the intersection of some $C(\rho, \sigma)$'s could be a proper subset of another $C(\rho', \sigma)$. Let $\overline{D(\mathcal{H}')}$ be the closure of $D(\mathcal{H}')$ in $X_{\mathbf{R}}$ and $D(\mathcal{H}')^0$ the relative interior of $\overline{D(\mathcal{H}')}$. Each $D(\mathcal{H}')^0$ is an open connected domain of $X_{\mathbf{R}}$. If $\mathcal{H}' = \emptyset$, then $D(\mathcal{H}') = \sigma$, while if $\mathcal{H}' = \mathcal{H}(\sigma)$, then $D(\mathcal{H}') = \emptyset$.

Let $|\mathcal{H}(\sigma)|$ be the union of all $H(\rho) \in \mathcal{H}(\sigma)$. The complement of $|\mathcal{H}(\sigma)|$ in $X_{\mathbf{R}}$ is the disjoint union of $D(\mathcal{H}')^0$, while $X_{\mathbf{R}}$ is the disjoint union of $D(\mathcal{H}')$.

Lemma 6.6. *Let $\sigma \in \text{Del}^{(g)}$ and $x \in X_{\mathbf{R}}$. Let $B_{\sigma}(x)$ be the union of all faces τ of σ such that $x \in C(\tau, \sigma)^c$. Then $B_{\sigma}(x)$ is the union of all $(g-1)$ -dimensional faces ρ of σ such that $x \in C(\rho, \sigma)^c$.*

Proof. Let τ^* be a face of σ . Then we remark that by the definition of $B_{\sigma}(x)$, $x \in C(\tau^*, \sigma)^c$ iff $\tau^* \subset B_{\sigma}(x)$. Let τ be a face of σ . Then τ is the intersection of all $(g-1)$ -dimensional faces of σ containing τ . By Lemma 6.3

$$C(\tau, \sigma) = \bigcap_{\rho \in \text{Del}_{\sigma}^{(g-1)}(\tau)} C(\rho, \sigma).$$

Hence $x \in C(\tau, \sigma)^c$ iff $x \in C(\rho, \sigma)^c$ ($\exists \rho \in \text{Del}_{\sigma}^{(g-1)}(\tau)$), and by the above remark, iff $\tau \subset \rho \subset B_{\sigma}(x)$ ($\exists \rho \in \text{Del}_{\sigma}^{(g-1)}$). This proves the lemma. Q.E.D.

Lemma 6.7. *Let $\sigma \in \text{Del}^{(g)}$. If $x \in \sigma$, then $B_{\sigma}(x) = \emptyset$.*

Proof. If $x \in \sigma$, then $x \in C(\tau, \sigma)$ for any $\tau \in \text{Del}_{\sigma}$. It follows that $B_{\sigma}(x) = \emptyset$. Q.E.D.

Lemma 6.8. *Let $\sigma \in \text{Del}^{(g)}$ and $x \in X_{\mathbf{R}} \setminus \sigma$. Then $B_{\sigma}(x)$ is nonempty, connected and contractible.*

This is a corollary to the following more general lemma.

Lemma 6.9. *Let Δ be a bounded convex polytope in $X_{\mathbf{R}} = \mathbf{R}^g$, \mathcal{H} the set of one-codimensional faces of Δ . For a one-codimensional face ρ of Δ we define $H(\rho)$ a hyperplane of $X_{\mathbf{R}}$ spanned by ρ , $C(\rho, \Delta)$ the closed half space of $X_{\mathbf{R}}$ bounded by $H(\rho)$ containing Δ , $C(\rho, \Delta)^c$ the complement of $C(\rho, \Delta)$ in $X_{\mathbf{R}}$. For any point x of $X_{\mathbf{R}} \setminus \Delta$. Let $B_{\Delta}(x)$ be the union of one-codimensional faces of Δ with $x \in C(\rho, \Delta)^c$. Then $B_{\Delta}(x)$ is connected and contractible.*

Proof. To explain our idea let us first suppose that Δ is a closed ball of dimension g . Let $\partial\Delta$ be the boundary of Δ , and x a point outside of Δ . Set a source of light at x and light the ball up from x . Let $B_{\Delta}(x)$ be the part of $\partial\Delta$ illuminated by the light. It is clear that $B_{\Delta}(x)$ is homeomorphic to a hemisphere, hence homeomorphic to a closed ball of dimension $g-1$.

Now we turn to the proof of our lemma. Let Δ be a convex polytope of dimension g , $\partial\Delta$ the boundary of it and x a point outside of Δ . Set a source of light at x and light the polytope Δ up from x . Then for

a one-codimensional face ρ of Δ , $x \in C(\rho, \Delta)^c$ iff ρ is illuminated by the light whose source is set at the point x . Here we regard that ρ is not illuminated by the light if the source of the light is set at a point x on the hyperplane $H(\rho)$ spanned by ρ . Since Δ is convex, the part of $\partial\Delta$ illuminated by the light is the union of ρ with $x \in C(\rho, \Delta)^c$, that is, $B_\Delta(x)$. This proves that $B_\Delta(x)$ is homeomorphic to a hemisphere, hence it is a nonempty connected contractible subset of $\partial\Delta$. Q.E.D.

Lemma 6.10. *Let $\sigma \in \text{Del}^{(g)}$ and $x \in X_{\mathbf{R}}$. Let $\sharp(\sigma \cap X) = N + 1$ and $\Delta(\sigma)$ an abstract N -dimensional simplex with vertices $\sigma \cap X$. For any subset S of $\sigma \cap X$, we define $\Delta(S)$ to be the subsimplex of $\Delta(\sigma)$ spanned by S , and $B_{\Delta(\sigma)}(x)$ be the union of all $\Delta(S)$ such that $x \in C(S, \sigma)^c$ and $S \subset \sigma \cap X$. Then*

- (i) $B_{\Delta(\sigma)}(x)$ is the union of $\Delta(\rho \cap X)$ for all $(g - 1)$ -dimensional faces ρ of σ such that $x \in C(\rho, \sigma)^c$.
- (ii) $B_{\Delta(\sigma)}(x)$ is nonempty, connected and contractible.

Proof. Let \mathbf{c} be cellmates and $\tau(\mathbf{c})$ the minimal face of σ such that $|\mathbf{c}| \subset \tau(\mathbf{c})$. Let $S = |\mathbf{c}|$. By Lemma 6.2, $C(S, \sigma) = C(\mathbf{c}, \sigma) = C(\tau(\mathbf{c}), \sigma)$. Hence by Lemma 6.6

$$\begin{aligned} \Delta(S) \subset B_{\Delta(\sigma)}(x) &\iff x \in C(S, \sigma)^c \\ &\iff x \in C(\tau(\mathbf{c}), \sigma)^c \\ &\iff \tau(\mathbf{c}) \subset B_\sigma(x) \\ &\iff \tau(\mathbf{c}) \subset \rho \subset B_\sigma(x) \quad (\exists \rho \in \text{Del}_\sigma^{(g-1)}) \\ &\iff S \subset \rho \subset B_\sigma(x) \quad (\exists \rho \in \text{Del}_\sigma^{(g-1)}) \\ &\iff \Delta(S) \subset \Delta(\rho \cap X) \subset B_{\Delta(\sigma)}(x) \quad (\exists \rho \in \text{Del}_\sigma^{(g-1)}). \end{aligned}$$

This proves (i). Next we prove (ii). By (i) $B_{\Delta(\sigma)}(x)$ is the union of $\Delta(\rho \cap X)$ such that $\rho \subset B_\sigma(x)$. For simplicity we denote $\Delta(\rho \cap X)$ by $\Delta(\rho)$.

Let $\rho \in \text{Del}_\sigma^{(g-1)}$ such that $\rho \subset B_\sigma(x)$. Since $\Delta(\rho)$ is an abstract simplex with vertices $\rho \cap X$, we have a natural map π_ρ from $\Delta(\rho)$ onto ρ . Thus for any vertex P of ρ , we have a vertex of $\Delta(\rho)$ mapped to P , which we denote by $\Delta(P)$. Let $\rho \cap X = \{P_0, \dots, P_r\}$. Then the natural map π_ρ from $\Delta(\rho)$ onto ρ is given by

$$\Delta(\rho) \ni t_0\Delta(P_0) + \dots + t_r\Delta(P_r) \mapsto t_0P_0 + \dots + t_rP_r \in \sigma$$

where $t_0 + \dots + t_r = 1$. When ρ ranges over the set of the faces contained in $B_\sigma(x)$, the natural maps π_ρ glue together to give rise to a natural surjective continuous polytope map $\pi : B_{\Delta(\sigma)}(x) \rightarrow B_\sigma(x)$. We prove

that any fibre of π is connected and contractible. Let ρ be the above Delaunay cell and P any point of ρ . Then the inverse image $\pi^{-1}(P)$ is the intersection of $\Delta(\rho)$ with an affine linear subspace $H_P : t_0P_0 + t_1P_1 + \cdots + t_rP_r = P$, ($t_0 + \cdots + t_r = 1$) in the (t_0, \dots, t_r) -space \mathbf{R}^{r+1} . The simplex $\Delta(\rho)$ is just the subset of \mathbf{R}^{r+1} defined by $t_0 + \cdots + t_r = 1$ and $0 \leq t_j \leq 1$ for any $j = 0, 1, \dots, r$. Since $\Delta(\rho)$ is convex, the intersection $H_P \cap \Delta(\rho) = \pi^{-1}(P)$ is connected and contractible. Since $B_\sigma(x)$ is connected and contractible, so is $B_{\Delta(\sigma)}(x)$. This proves (ii). Q.E.D.

Theorem 6.11. *Let $x \in X$, $\sigma \in \text{Del}^{(g-k)}$ and let ${}_nF_\sigma^{k,\cdot}$ be the complex defined in Definition 5.13. Let $\Delta(\sigma)$ be the abstract simplex with vertices $\sigma \cap X$. Then*

$$\begin{aligned} \mathbf{H}^q({}_nF_\sigma^{k,\cdot}[x], \delta_n^{k,\cdot}) &\simeq \mathbf{H}^q(C(\Delta(\sigma), B_{\Delta(\sigma)}(\frac{x}{n}))) \\ &= \begin{cases} k(0) & \text{if } q = 0 \text{ and } \frac{x}{n} \in \sigma \\ 0 & \text{otherwise} \end{cases} \end{aligned}$$

Proof. Since the coboundary operator $\delta_n^{k,q}$ of the complex ${}_nF_\sigma^{k,\cdot}$ is (regarded as) homogeneous in the sense we are going to explain, it suffices to compute the cohomology of the complex for a fixed weight $x \in X$.

Let $f \in {}_nF_\sigma^{k,q}$ and $g = \delta_n^{k,q}(f)$. Then by the definition of the coboundary operator $\delta_n^{k,q}$ we have the equality as

$$\begin{aligned} \xi_{c_0}^n g(c_0, c_1, \dots, c_{q+1}) &= \xi_{c_1}^n f(c_1, c_2, \dots, c_{q+1}) \\ &\quad + \sum_{j=1}^{q+1} (-1)^j \xi_{c_0}^n f(c_0, \dots, \hat{c}_j, \dots, c_{q+1}), \end{aligned}$$

which is homogeneous with regard to the weights X .

Let $\sigma \in \text{Del}^{(g-k)}$. Let ${}_nF_\sigma^{k,q}(\mathbf{c})[x]$ be the weight x -part of ${}_nF_\sigma^{k,q}(\mathbf{c})$ in the above sense. For brevity we first consider the case $\frac{x}{n} \in \sigma \cap \frac{X}{n}$.

Let $\mathbf{c} = (c_0, \dots, c_q)$ be cellmates with $|\mathbf{c}| \subset \sigma$. Then $\xi(x - nc_0, \mathbf{c}) = \xi(x - nc_0, c_0)$ by Lemma 5.10. We see that

$$\begin{aligned} \frac{x}{n} \in \sigma \cap \frac{X}{n} &\iff \frac{x}{n} \in C(c, \sigma) \cap \frac{X}{n} \quad (\forall c \in \sigma \cap X) \\ &\iff \frac{x}{n} - c \in C(0, \sigma - c) \cap \frac{X}{n} \quad (\forall c \in \sigma \cap X) \\ &\iff x - nc \in C(0, \sigma - c) \cap X \quad (\forall c \in \sigma \cap X) \\ &\iff (x - nc) + c \in C(c, \sigma) \cap X \quad (\forall c \in \sigma \cap X). \end{aligned}$$

If $\frac{x}{n} \in \sigma \cap \frac{X}{n}$, then $(x - nc) + c \in C(c, \sigma) \cap X \subset C(\mathbf{c}, \sigma) \cap X$. Hence

$${}_nF_\sigma^{k,q}(\mathbf{c})[x] = k(0) \cdot \xi(x - nc_0, \mathbf{c}) = k(0) \cdot \xi(x - nc_0, c_0)$$

by Definition 5.9. Hence we have

$${}_nF_\sigma^{k,q}[x] = \bigoplus_{\substack{|\mathbf{c}| \subset \sigma \\ \ell(\mathbf{c}) = q}} {}_nF_\sigma^{k,q}(\mathbf{c})[x] = \bigoplus_{\substack{|\mathbf{c}| \subset \sigma \\ \ell(\mathbf{c}) = q}} k(0) \Delta(\mathbf{c})^*$$

where $\Delta(\mathbf{c})^*$ is the dual cochain of an abstract q -simplex $\Delta(\mathbf{c})$ with vertices $|\mathbf{c}|$ and $\ell(\mathbf{c}) = q$. Thus we see that the complex $(F_\sigma^{k,\cdot}[x], \delta^{k,\cdot})$ is isomorphic to the standard cochain complex over $k(0)$ of an abstract N -simplex $\Delta(\sigma)$ with vertices $\sigma \cap X$.

Let $N = \sharp(\sigma \cap X) - 1$. We note that N could be different from the real dimension of σ . Since the N -simplex $\Delta(\sigma)$ is contractible to one point, we have

$$\mathbf{H}^q({}_nF_\sigma^{k,\cdot}[x], \delta^{k,\cdot}) = \begin{cases} k(0) \cdot [x] & \text{if } q = 0 \\ 0 & \text{if } q > 0. \end{cases}$$

where $[x]$ denotes the (unique) monomial generator $\xi_c^n \xi(x - nc, c)$ of weight x , independent of the choice of c ($c \in \sigma \cap X$). This proves the theorem when $\frac{x}{n} \in \sigma \cap \frac{X}{n}$.

Now we consider the general case. For $\sigma \in \text{Del}^{(g-k)}$ we define $H(\sigma) := \sigma + X(\sigma) \otimes \mathbf{R}$. Note that $\dim H(\sigma) = g - k = \dim \sigma$. First we prove that for any $x \in H(\sigma) \cap X$

$${}_nF_\sigma^{k,q}(\mathbf{c})[x] = \begin{cases} k(0) \cdot \xi(x - nc_0, \mathbf{c}) & \text{if } \frac{x}{n} \in C(\mathbf{c}, \sigma) \\ 0 & \text{otherwise} \end{cases}$$

where $\mathbf{c} = (c_0, \dots, c_q)$. In fact, ${}_nF_\sigma^{k,q}(\mathbf{c})[x] = k(0) \cdot \xi(x - nc_0, \mathbf{c})$ iff $x - nc_0 + c_0 \in C(\mathbf{c}, \sigma)$ by the definition of ${}_nF_\sigma^{k,q}$. We also see

$$\begin{aligned} x - nc_0 + c_0 \in C(\mathbf{c}, \sigma) &\iff x - nc_0 \in C(0, \sigma - c_0) + X(\mathbf{c})_{\mathbf{R}} \\ &\iff \frac{x}{n} - c_0 \in C(0, \sigma - c_0) + X(\mathbf{c})_{\mathbf{R}} \\ &\iff \frac{x}{n} \in C(\mathbf{c}, \sigma). \end{aligned}$$

Therefore ${}_nF_\sigma^{k,q}(\mathbf{c})[x] \simeq k(0)$ iff $\frac{x}{n} \in C(\mathbf{c}, \sigma)$.

We recall the modified generator $\xi_{c_0}^n \xi(x - nc_0, \mathbf{c}) = \xi_{c_0}^n \xi(x - nc_0, c_0)$ is independent of the choice of both $c_0 \in \mathbf{c}$ and \mathbf{c} , and it depends only

on σ (Lemma 5.10) because $\xi_{c_0}^n \xi(x - nc_0, c_0)$ and $\xi_{c_1}^n \xi(x - nc_1, c_1)$ are identified in ${}_n F_\sigma^{k,q}$ by Definition 5.13.

Let $\sigma \in \text{Del}^{(g-k)}$ and cellmates \mathbf{c} such that $|\mathbf{c}| \subset \sigma$. Then by Lemma 6.2 we see

$$\begin{aligned} {}_n F_\sigma^{k,q}(\mathbf{c})[x] = 0 &\iff \frac{x}{n} \in C(\mathbf{c}, \sigma)^c \iff \frac{x}{n} \in C(\tau(\mathbf{c}), \sigma)^c \\ &\iff \tau(\mathbf{c}) \subset B_\sigma\left(\frac{x}{n}\right) \iff |\mathbf{c}| \subset B_\sigma\left(\frac{x}{n}\right) \end{aligned}$$

where $q = \ell(\mathbf{c})$, $\tau(\mathbf{c})$ is the minimal face of σ such that $|\mathbf{c}| \subset \tau$. It follows that

$${}_n F_\sigma^{k,q}(\mathbf{c})[x] \simeq k(0) \iff |\mathbf{c}| \not\subset B_\sigma\left(\frac{x}{n}\right).$$

Thus there is an isomorphism of $k(0)$ -modules

$${}_n F_\sigma^{k,q}[x] := \bigoplus_{\substack{\ell(\mathbf{c})=q \\ |\mathbf{c}| \subset \sigma}} {}_n F_\sigma^{k,q}(\mathbf{c})[x] \simeq C^q(\Delta(\sigma), B_{\Delta(\sigma)}\left(\frac{x}{n}\right))$$

It is easy to see that this induces an isomorphism between the complex ${}_n F_\sigma^{k,\cdot}[x]$ and the relative cochain complex $C^\cdot(\Delta(\sigma), B_{\Delta(\sigma)}\left(\frac{x}{n}\right))$. By Lemma 6.10 if $B_{\Delta(\sigma)}\left(\frac{x}{n}\right)$ is nonempty, then $H^q(\Delta(\sigma), B_{\Delta(\sigma)}\left(\frac{x}{n}\right)) = 0$ for any q . If $B_{\Delta(\sigma)}\left(\frac{x}{n}\right)$ is empty ($\iff \frac{x}{n} \in \sigma$), then $H^q(\Delta(\sigma), B_{\Delta(\sigma)}\left(\frac{x}{n}\right)) = k(0)$ (resp. 0) for $q = 0$ (resp. $q > 0$). It follows that

$$\begin{aligned} \mathbf{H}^q({}_n F_\sigma^{k,\cdot}[x]) &= \mathbf{H}^q(C^\cdot(\Delta(\sigma), B_{\Delta(\sigma)}\left(\frac{x}{n}\right))) \\ &= \begin{cases} k(0) & \text{if } q = 0 \text{ and } \frac{x}{n} \in \sigma \\ 0 & \text{otherwise.} \end{cases} \end{aligned}$$

This completes the proof of Theorem 6.11, hence of Theorem 5.15.
Q.E.D.

Example 6.12. Here is an example. Let $k = k(0)$, $g = 2$, $X = \mathbf{Z}e_1 + \mathbf{Z}e_2$ and $B(x, x) = 2(x_1^2 - x_1x_2 + x_2^2)$ for $x = x_1e_1 + x_2e_2 \in X$. Let

$$\begin{aligned} e_1 &= (1, 0), \quad e_2 = (0, 1), \quad c_0 = 0, \quad c_1 = e_1, \quad c_2 = e_1 + e_2, \\ c_3 &= e_2, \quad c_4 = -e_1, \quad c_5 = -e_1 - e_2, \quad c_6 = -e_2. \end{aligned}$$

Let σ (resp. σ') be the convex closure $\langle c_0, c_1, c_2 \rangle$ (resp. $\langle c_0, c_2, c_3 \rangle$). Any Delaunay two-cell is a translate by X of either σ or σ' . Star(0) is the convex closure of c_j ($j = 1, \dots, 6$), which is a hexagon with the six vertices c_j .

There are essentially different three cases

- (i) $x \in \sigma$,
- (ii) $x \in C(c_0, \sigma) \setminus \sigma$,
- (iii) $x \in C(c_0, c_1, \sigma) \setminus \bigcup_{i=0,1} C(c_i, \sigma)$.

In the case (i) $B_\sigma(x) = \emptyset$. In the case (ii) $B_\sigma(x) = \langle c_1, c_2 \rangle$. In the case (iii) $B_\sigma(x) = \langle c_0, c_2 \rangle \cup \langle c_1, c_2 \rangle$. In the cases (ii) and (iii) $B_\sigma(x)$ is connected and contractible.

§7. The E_8 lattice

In this section we recall the notation for E_8 [Bourbaki, pp. 268-270]. Let \mathbf{Z}^8 be the lattice of rank 8 with the standard inner product, e_j ($1 \leq j \leq 8$) an orthogonal basis of it, and $(\frac{1}{2}\mathbf{Z})^8$ the overlattice spanned by $\frac{1}{2}e_j$ ($1 \leq j \leq 8$) with inner product induced naturally from that of \mathbf{Z}^8 . Then the sublattice X of $(\frac{1}{2}\mathbf{Z})^8$ is defined to be

$$\left\{ \sum_{i=1}^8 x_i e_i ; 2x_i \in \mathbf{Z}, x_i + x_j \in \mathbf{Z}, \sum_{i=1}^8 x_i \in 2\mathbf{Z} \right\}$$

with bilinear form inherited from $(\frac{1}{2}\mathbf{Z})^8$. This is the lattice E_8 .

Let $\{\alpha_j, j = 1, \dots, 8\}$ be a positive root system

$$\begin{aligned} \alpha_1 &= \frac{1}{2}(e_1 + e_8 - (e_2 + \dots + e_7)), \\ \alpha_2 &= e_1 + e_2, \quad \alpha_j = e_{j-1} - e_{j-2} \quad (3 \leq j \leq 8) \end{aligned}$$

The maximal root α_0 of the root system is given by

$$\alpha_0 = e_7 + e_8 = 2\alpha_1 + 3\alpha_2 + 4\alpha_3 + 6\alpha_4 + 5\alpha_5 + 4\alpha_6 + 3\alpha_7 + 2\alpha_8 (= \omega_8).$$

We define m_j ($1 \leq j \leq 8$) to be the multiplicity of α_j in α_0 . Thus for instance, $m_1 = 2, m_2 = 3$ and $m_3 = 4$. The root diagram of α_j ($1 \leq j \leq 8$) is E_8 , while the root diagram of α_j ($0 \leq j \leq 8$) is the extended Dynkin diagram \tilde{E}_8 given below

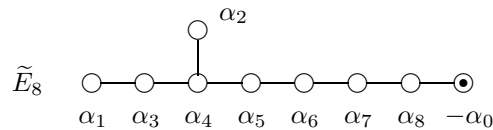

We also define the dual roots $\omega_k \in X$ by $(\alpha_j, \omega_k) = \delta_{jk}$. Hence we have

$$\begin{aligned} \omega_1 &= 2e_8, & \omega_2 &= \frac{1}{2}(e_1 + e_2 + \cdots + e_7 + 5e_8), \\ \omega_3 &= \frac{1}{2}(-e_1 + e_2 + \cdots + e_7 + 7e_8), & \omega_4 &= e_3 + e_4 + \cdots + e_7 + 5e_8, \\ \omega_5 &= e_4 + \cdots + e_7 + 4e_8, & \omega_6 &= e_5 + \cdots + e_7 + 3e_8, \\ \omega_7 &= e_6 + e_7 + 2e_8, & \omega_8 &= e_7 + e_8. \end{aligned}$$

For any $\alpha \in X (\neq 0)$ we define a hyperplane H_α of $X \otimes \mathbf{R}$ to be $H_\alpha = \{x \in X_{\mathbf{R}}; \alpha(x) = 0\}$ and the linear transformation r_α of $X \otimes \mathbf{R}$ to be the reflection with regards to H_α :

$$r_\alpha(x) = x - \frac{2(\alpha, x)}{(\alpha, \alpha)}\alpha.$$

If α is a root of E_8 , then $r_\alpha(x) = x - (\alpha, x)\alpha$. We also define r_0 to be

$$r_0(x) = x + (1 - (\alpha_0, x))\alpha_0.$$

Then r_0 is a reflection of $X_{\mathbf{R}}$ with regards to the hyperplane $H_0 := \{x \in X_{\mathbf{R}}; (\alpha_0, x) = 1\}$. The seven reflections r_{α_j} ($1 \leq j \leq 7$) generate the Weyl group $W(E_8)$, while the eight reflections r_0 and r_{α_j} ($1 \leq j \leq 7$) generate the affine Weyl group $W(\tilde{E}_8)$. The order of $W(E_8)$ equals $2^{14} \cdot 3^5 \cdot 5^2 \cdot 7$, while $W(\tilde{E}_8)$ is of infinite order. We note that r_{α_j} keeps ω_k ($k \neq j$) invariant because $(\alpha_j, \omega_k) = 0$.

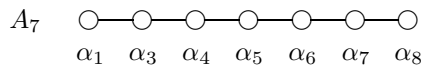
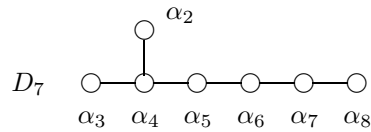
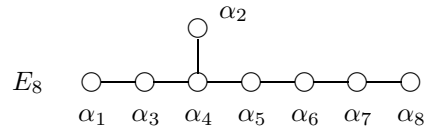

The diagram D_7 is a subdiagram of E_8 obtained by deleting α_1 . Therefore $W(D_7)$ is a subgroup of $W(E_8)$ naturally. Similarly since A_7 is E_8 with α_2 deleted, $W(A_7)$ is a subgroup of $W(E_8)$. For a group W acting on X , let $\text{Stab}_W(\omega)$ (resp. $\text{Stab}_W(\omega, \omega')$) be the stabilizer subgroup of W of $\omega \in X$ (resp. of both ω and $\omega' \in X$). Then $\text{Stab}_{W(E_8)}(\frac{\omega_1}{2}) = W(D_7)$ where $D_7 = E_8 \setminus \{\alpha_1\}$ because by [Bourbaki, Ch. 5, Prop. 2. p. 75] it is generated by the reflections r_α with roots α orthogonal to ω_1 . Similarly we see $\text{Stab}_{W(E_8)}(\frac{\omega_2}{3}) = W(A_7)$ where $A_7 = E_8 \setminus \{\alpha_2\}$.

§8. Elements of the lattice E_8

Let X be the lattice E_8 , $a, b \in X$, (a, b) the bilinear form of E_8 and $a^2 = (a, a)$. We call $\sqrt{a^2}$ the length of a , which we denote $\|a\|$. An element $a \in X$ is called a root (of E_8) if $a^2 = 2$, equivalently, the length of a equals $\sqrt{2}$.

Lemma 8.1. Any element $a \in X$ with $a^2 = 2$ is one of 240 roots:

- (i) $\pm e_i \pm e_j$ ($1 \leq i < j \leq 8$),
- (ii) $\frac{1}{2}(\sum_{j=1}^8 (-1)^{\nu(j)} e_j)$ with $\sum_j \nu(j)$ even.

Any of them is $W(E_8)$ -equivalent.

Proof. Any root $\alpha \in X$ with $\alpha^2 = 2$ is one of (i) and (ii). The number of these elements totals $112 + 128 = 240$, as is seen easily. Let $\alpha_0 = e_7 + e_8$ be the maximal root. Then $\text{Stab}_{W(E_8)}(\alpha_0) = W(E_7)$ by [Bourbaki, p. 75], whence the number of roots is equal to $|W(E_8)/W(E_7)|$ ($= 2^{14} \cdot 3^5 \cdot 5^2 \cdot 7/2^{10} \cdot 3^4 \cdot 5 \cdot 7 = 240$). Hence the set of roots is transitive under $W(E_8)$. Q.E.D.

Lemma 8.2. Any element $a \in X$ with $a^2 = 4$ is one of the following

- (i) $\pm 2e_k$ ($1 \leq k \leq 8$),
- (ii) $\pm e_i \pm e_j \pm e_k \pm e_\ell$ ($1 \leq i < j < k < \ell \leq 8$),
- (iii) $\pm \frac{1}{2}(3e_i + \sum_{j \neq i} (-1)^{\nu(j)} e_j)$ with $\sum_{j \neq i} \nu(j)$ odd.

Any of them is $W(E_8)$ -equivalent.

Proof. Let $a_0 = 2e_8$. By [Bourbaki, p. 75] $\text{Stab}_{W(E_8)}(a_0) = W(D_7)$, the subgroup of $W(E_8)$ generated by r_{α_j} ($j \geq 2$) because $(a_0, \alpha_j) = 0$ for $j \neq 1$. Hence the orbit $W(E_8) \cdot a_0$ consists of 2160 elements where $2160 = |W(E_8)/W(D_7)|$. Meanwhile the number of the elements of type (i), (ii) and (iii) are respectively 16, $1120 = 2^4 \cdot \binom{8}{4}$ and $1024 = 2^7 \cdot \binom{8}{1}$ which totals 2160. This shows that the above 2160 elements are in the single $W(E_8)$ -orbit of a_0 . Q.E.D.

Lemma 8.3. *Any element $a \in X$ with $a^2 = 6$ is one of the following*

- (i) $\pm e_i \pm e_j \pm 2e_k$ for i, j, k all distinct
- (ii) $\sum_{k=1}^6 \pm e_{i_k}$ ($1 \leq i_k \leq 8$) for i_k all distinct
- (iii) $\pm \frac{1}{2}(3e_i + 3e_j + \sum_{k \neq i, j} (-1)^{\nu(k)} e_k)$ with $\sum_{k \neq i, j} \nu(k)$ even.

Any of them is $W(E_8)$ -equivalent.

Proof. Let $a_0 = e_6 + e_7 + 2e_8$. By [Bourbaki, p. 75] $\text{Stab}_{W(E_8)}(a_0) = W(A_1 \times E_6)$, where the subgroup of $W(E_6)$ is generated by r_{α_j} ($1 \leq j \leq 6$) and $W(A_1)$ is generated by r_{α_8} because $(a_0, \alpha_j) = 0$ for $j \neq 7$. Hence the orbit $W(E_8) \cdot a_0$ consists of $|W(E_8)/W(A_1)| |W(E_6)| = 2^{14} \cdot 3^5 \cdot 5^2 \cdot 7/2^8 \cdot 3^4 \cdot 5 = 6720$ elements. Meanwhile the number of the elements of type (i), (ii) and (iii) are respectively $1344 = 2^3 \cdot \binom{8}{1} \cdot \binom{7}{2}$, $1792 = 2^6 \cdot \binom{8}{6}$ and $3584 = 2^7 \cdot \binom{8}{2}$ which totals 6720. This shows that the above 6720 elements are in the single $W(E_8)$ -orbit of a . Q.E.D.

Lemma 8.4. *Any pair of $a, b \in X$ with $a^2 = b^2 = 2$ and $(a, b) = 0$ is $W(E_8)$ -equivalent.*

Proof. We may assume $a = e_7 + e_8 (= \alpha_0)$. Then $b \in X$ satisfying the conditions $b^2 = 2$ and $(a, b) = 0$ are one of the following

- (i) $\pm e_i \pm e_j$ for $i, j \in \{1, 2, 3, 4, 5, 6\}$ and $i < j$,
- (ii) $\pm(e_7 - e_8)$,
- (iii) $\frac{1}{2}(\sum_{j=1}^8 (-1)^{\nu_j} e_j)$ with $\sum_j \nu_j$ even, $\nu_7 + \nu_8 = 1$.

One counts the number of elements of (i), (ii) and (iii) respectively as 60, 2 and 64. These total 126. Meanwhile let $\beta = -e_7 + e_8$. Then β is a root with $(\alpha_0, \beta) = 0$ and $\text{Stab}_{W(E_8)}(\alpha_0) = W(E_7)$, $\text{Stab}_{W(E_8)}(\alpha_0, \beta) = \text{Stab}_{W(E_7)}(\beta) = W(D_6)$ by [Bourbaki, p. 75] because the subspace of X orthogonal to α_0 and β is spanned by α_j ($2 \leq j \leq 7$). Let F be the subset of roots b of E_8 with $(a, b) = 0$. We want to prove that there is $\sigma \in W(E_8)$ such that $a = \sigma(\alpha_0)$ and $b = \sigma(\beta)$. Since a is in the $W(E_8)$ -orbit of α_0 by Lemma 8.1, we may assume $a = \alpha_0$. We see $|\text{Stab}_{W(E_8)}(\alpha_0) \cdot \beta| = |\text{Stab}_{W(E_8)}(\alpha_0) / \text{Stab}_{W(E_8)}(\alpha_0, \beta)| = |W(E_7)/W(D_6)| = 2^{10} \cdot 3^4 \cdot 5 \cdot 7/2^5 \cdot 6! = 2 \cdot 3^2 \cdot 7 = 126$. It follows that the orbit $\text{Stab}_{W(E_8)}(\alpha_0) \cdot \beta$ consists of 126 elements. Hence $\text{Stab}_{W(E_8)}(\alpha_0)$ acts transitively on the set F . This completes the proof. Q.E.D.

Lemma 8.5. *Any pair of $a, b \in X$ with $a^2 = 4, b^2 = 2$ and $(a, b) = 0$ is $W(E_8)$ -equivalent to $a = 2e_8$ and $b = -e_6 + e_7$.*

Proof. We may assume $a = 2e_8$ by Lemma 8.2. Let F be the set of all b with $b^2 = 2$ and $(a, b) = 0$. It is the set of all roots of D_7 , $F = \{\pm e_i \pm e_j; 1 \leq i < j \leq 7\}$ where $D_7 = E_8 \setminus \{\alpha_1\}$. It follows

$\text{Stab}_{W(E_8)}(2e_8) = W(D_7)$. Since $W(D_7)$ acts on F transitively, so acts $\text{Stab}_{W(E_8)}(2e_8)$ on F . This proves the lemma. Q.E.D.

Lemma 8.6. *Any pair of $a, b \in X$ with $a^2 = 4, b^2 = 2$ and $(a, b) = 1$ is $W(E_8)$ -equivalent to $a = 2e_8$ and $b = \frac{1}{2}(\sum_{j=1}^8 e_j)$.*

Proof. We may assume $a = 2e_8$ by Lemma 8.2. Let F be the set of all $b \in X$ with $b^2 = 2$ and $(a, b) = 1$. Then $F = \{\frac{1}{2}(\sum_{j=1}^7 (-1)^{\nu_j} e_j + e_8); \sum_{j=1}^7 \nu_j \text{ even}\}$. We see $|F| = 64$. Let $b = \frac{1}{2}(e_1 + e_2 + \dots + e_8)$. Then we see $\text{Stab}_{W(E_8)}(a) = W(D_7)$ and $\text{Stab}_{W(E_8)}(a, b) = W(A_6)$ where $A_6 = D_7 \setminus \{\alpha_2\}$ because the subspace of X orthogonal to a and b is spanned by α_j ($3 \leq j \leq 8$). It follows that the orbit $\text{Stab}_{W(E_8)}(a) \cdot b$ consists of $|\text{Stab}_{W(E_8)}(a)/\text{Stab}_{W(E_8)}(a, b)| = |W(D_7)/W(A_6)| = 2^6 \cdot 7!/7! = 64$ elements. This implies that the action of $\text{Stab}_{W(E_8)}(a)$ on F is transitive. Q.E.D.

Corollary 8.7. *Any pair of $a, b \in X$ with $a^2 = 4, b^2 = 2$ and $(a, b) = 1$ is $W(E_8)$ -equivalent to $a = e_5 + e_6 + e_7 + e_8$ and $b = e_4 + e_8$.*

Lemma 8.8. *Any pair of $a, b \in X$ with $a^2 = 4, b^2 = 2$ and $(a, b) = 2$ is $W(E_8)$ -equivalent to $a = 2e_8$ and $b = e_7 + e_8$.*

Proof. We may assume $a = 2e_8$ by Lemma 8.2. Let F be the set of all $b \in X$ with $b^2 = 2$ and $(a, b) = 2$. Then $F = \{\pm e_j + e_8; 1 \leq j \leq 7\}$ and $|F| = 14$. Let $b = e_7 + e_8$. Then $b \in F$ and $\text{Stab}_{W(E_8)}(a) = W(D_7)$, $\text{Stab}_{W(E_8)}(a, b) = W(D_6)$ where $D_6 = D_7 \setminus \{\alpha_8\}$. It follows that the orbit $\text{Stab}_{W(E_8)}(a) \cdot b$ consists of $|\text{Stab}_{W(E_8)}(a)/\text{Stab}_{W(E_8)}(a, b)| = |W(D_7)/W(D_6)| = 2^6 \cdot 7!/2^5 \cdot 6! = 14$ elements. This implies that the action of $\text{Stab}_{W(E_8)}(a)$ on F is transitive. Q.E.D.

Lemma 8.9. *Let $\{a_k, a_{k+1}, \dots, a_7\}$ ($1 \leq k \leq 7$) be a set of roots such that $(a_i, a_j) = 1$ for any $i \neq j$. Up to $W(E_8)$,*

- (i) *if $k \geq 2$, it is equivalent to the set $\{e_k + e_8, e_{k+1} + e_8, \dots, e_7 + e_8\}$.*
- (ii) *if $k = 1$, then it is equivalent to either $\{e_1 + e_8, e_2 + e_8, \dots, e_7 + e_8\}$ or $\{-e_1 + e_8, e_2 + e_8, \dots, e_7 + e_8\}$.*

Proof. We prove the lemma by the descending induction on k . The case $k = 7$ follows from Lemma 8.2. Let $\beta_j = e_j + e_8$ ($1 \leq j \leq 7$). Next we consider the case $k = 6$. We may assume $a_7 = \beta_7$ by Lemma 8.2. Let F be the set of all a with $(a, a) = 2$ and $(a, a_7) = 1$. Then $|F| = 56$. Then $\beta_6 \in F$. Since $\text{Stab}_{W(E_8)}(\beta_7) = W(E_7)$ and $\text{Stab}_{W(E_7)}(\beta_6) = W(E_6)$ where $E_6 = E_8 \setminus \{\alpha_6, \alpha_7\}$, we see $W(E_7) \cdot \beta_6 = |W(E_7)/W(E_6)| = 2^{10} \cdot 3^4 \cdot 5 \cdot 7/2^7 \cdot 3^4 \cdot 5 = 56$. This shows that $W(E_7)$ acts transitively on F . This proves the lemma for $k = 6$.

Next we consider the case $k = 5$. We may assume $a_6 = \beta_6$ and $a_7 = \beta_7$ by the induction hypothesis. There are exactly 27 roots a with $(a, \beta_6) = (a, \beta_7) = 1$. Meanwhile $\text{Stab}_{W(E_6)}(\beta_5) = W(D_5)$ and $|W(E_6)/W(D_5)| = 2^7 \cdot 3^4 \cdot 5/2^4 \cdot 5! = 27$ where $D_5 = \{\alpha_j; 1 \leq j \leq 5\}$. This proves the case $k = 5$.

There are exactly 16 roots a with $(a, \beta_j) = 1$ ($j = 5, 6, 7$). Meanwhile $\text{Stab}_{W(D_5)}(\beta_4) = W(A_4)$ and $|W(D_5)/W(A_4)| = 2^4 \cdot 5!/5! = 16$ where $A_4 = \{\alpha_j; 1 \leq j \leq 4\}$. This proves the case $k = 4$. Similarly there are exactly 10 roots a with $(a, \beta_j) = 1$ for $4 \leq j \leq 7$, while $\text{Stab}_{W(A_4)}(\beta_3) = W(A_2 \times A_1)$ and $|W(A_4)/W(A_2 \times A_1)| = 10$ where $A_2 \times A_1 = \{\alpha_1, \alpha_2, \alpha_3\}$. This proves the case $k = 3$. When $k = 2$, there are exactly 6 roots a with $(a, \beta_j) = 1$ for $3 \leq j \leq 7$, and $\text{Stab}_{W(A_2 \times A_1)}(\beta_2) = W(A_1)$ and $|W(A_2 \times A_1)/W(A_1)| = 6$ where $A_1 = \{\alpha_1\}$. Hence the case of $k = 2$ is proved.

If $k = 1$, we may suppose $a_j = \beta_j$ for $2 \leq j \leq 7$ by the induction hypothesis. Then there are three choices $a_1 = \pm e_1 + e_8$ and $\frac{1}{2}(e_1 + \cdots + e_8)$. Since $A_1 = \{\alpha_1\}$, $W(A_1)$ is generated by r_{α_1} and $r_{\alpha_1}(-e_1 + e_8) = -e_1 + e_8$, $r_{\alpha_1}(e_1 + e_8) = \frac{1}{2}(e_1 + \cdots + e_8)$. This shows that there are two $W(A_1)$ -orbits. This completes the proof of the lemma. Q.E.D.

Corollary 8.10. *Any sublattice A_{8-k} of E_8 is $W(E_8)$ -equivalent to the sublattice $\{\alpha_k, \dots, \alpha_8, -\alpha_0\}$ if $k \geq 2$. If $k = 1$ and if there is no root orthogonal to the sublattice, then it is $W(E_8)$ -equivalent to $\{\alpha_3, \alpha_4, \dots, \alpha_8, -\alpha_0\}$. If $k = 1$ and if there is a root orthogonal to the sublattice, then it is $W(E_8)$ -equivalent to $\{\alpha_2, \alpha_4, \dots, \alpha_8, -\alpha_0\}$.*

Proof. Let X_k be the sublattice of $X = E_8$ isomorphic (as a lattice) to A_{8-k} . Hence there is a basis b_j of X_k ($k \leq j \leq 7$) such that $(b_j, b_{j+1}) = -1$, $(b_j, b_j) = 2$ and $(b_i, b_j) = 0$ (otherwise). Let $\gamma_7 = -b_7$ and $\gamma_j = -\sum_{\ell=j}^7 b_\ell$ ($k \leq j \leq 7$). We note that $b_7 = -\gamma_7$ and $b_j = \gamma_{j+1} - \gamma_j$ ($k \leq j \leq 6$). Then we see $(\gamma_i, \gamma_i) = 2$ and $(\gamma_i, \gamma_j) = 1$ for any $i \neq j$. Hence if $k \geq 2$, the ordered set $\{\gamma_j; k \leq j \leq 7\}$ is $W(E_8)$ -equivalent to $\{e_k + e_8, e_{k+1} + e_8, \dots, e_7 + e_8\}$ by Lemma 8.9. It follows that the ordered set $\{b_j; k \leq j \leq 7\}$ is $W(E_8)$ -equivalent to $\{\alpha_{k+2}, \alpha_{k+3}, \dots, \alpha_8, -\alpha_0\}$. When $k = 1$, then the ordered set $\{\gamma_j; k \leq j \leq 7\}$ is $W(E_8)$ -equivalent to either $\{e_1 + e_8, e_2 + e_8, \dots, e_7 + e_8\}$ or $\{-e_1 + e_8, e_2 + e_8, \dots, e_7 + e_8\}$ by Lemma 8.9. It follows that the ordered set $\{b_j; 1 \leq j \leq 7\}$ is $W(E_8)$ -equivalent to either $\{\alpha_3, \alpha_4, \dots, \alpha_8, -\alpha_0\}$ or $\{\alpha_2, \alpha_4, \dots, \alpha_8, -\alpha_0\}$. This proves the corollary. Q.E.D.

Lemma 8.11. *For a given set $\{a_1, a_2, \dots, a_7\}$ as in Lemma 8.9 there are at most two elements $\omega \in X$ such that $\omega^2 = 4$ and $(\omega, a_j) = 2$*

for any $j \leq 7$. If $a_j = e_j + e_8$ ($1 \leq j \leq 7$), then $\omega = 2e_8$. If $a_1 = -e_1 + e_8$ and $a_j = e_j + e_8$ ($2 \leq j \leq 7$), then $\omega = 2e_8$ or $\omega = \frac{1}{2}(-e_1 + e_2 + \dots + 3e_8)$.

Proof. It suffices to prove the lemma up to $W(E_8)$ -equivalence. Hence by Lemma 8.9 we may assume $a_1 = \pm e_1 + e_8$ and $a_j = e_j + e_8$ ($j \geq 2$). In either case $\omega = 2e_8$ satisfies the conditions. If $a_1 = -e_1 + e_8$ and $a_j = e_j + e_8$ ($j \geq 2$), then $\omega = \frac{1}{2}(-e_1 + e_2 + \dots + 3e_8)$ also satisfies the conditions. Suppose ω satisfies the conditions. Let $s = \omega - a_1$. It follows from $(\omega, \omega) = 4$ that $(s, s) = 2$. Moreover $(s, a_j) = 1$ for any $j \leq 7$, which implies $s = \pm e_1 + e_8$ or $s = \frac{1}{2}(e_1 + \dots + e_8)$. Hence if $a_1 = e_1 + e_8$, then $s = -e_1 + e_8$ and $\omega = 2e_8$. If $a_1 = -e_1 + e_8$, then $s = e_1 + e_8$ or $s = \frac{1}{2}(e_1 + \dots + e_8)$. Therefore $\omega = 2e_8$ or $\frac{1}{2}(-e_1 + e_2 + \dots + 3e_8)$. Q.E.D.

We note that if we let $s_j := \omega - a_j$ ($1 \leq j \leq 7$) in Lemma 8.11, then s_j satisfies $(s_j, s_k) = 1 + \delta_{jk}$ and $(s_j, a_k) = 1 - \delta_{jk}$. We call $a \in X$ primitive if a is not an integral multiple of any element of X .

Lemma 8.12. *There are 17280 primitive elements $a \in X$ with $a^2 = 8$. Any element $a \in X$ with $a^2 = 8$ is one of the following*

- (i) $\sum_{k=1}^4 (-1)^{\nu(i_k)} e_{i_k} + (-1)^{\nu(m)} 2e_m$ (i_k, m all distinct),
- (ii) $\sum_{i=1}^8 (-1)^{\nu(i)} e_i$ with $\sum_{i=1}^8 \nu(i)$ odd,
- (iii) $\pm \frac{1}{2}(\sum_{i \neq k} (-1)^{\nu(i)} e_i + 5e_k)$ with $\sum_{i \neq k} \nu(i)$ even,
- (iv) $\frac{1}{2}(\sum_{i \neq j, k, \ell} (-1)^{\nu(i)} e_i) + \frac{3}{2}(\sum_{i=j, k, \ell} (-1)^{\nu(i)} e_i)$ with $\sum_{i=1}^8 \nu(i)$ odd.

Any of them is $W(E_8)$ -equivalent.

Proof. Let $\text{Stab}_{W(E_8)}(\omega_2)$ be the stabilizer subgroup of ω_2 . By [Bourbaki, p. 75] it is the subgroup of $W(E_8)$ generated by r_α ($\alpha \in X$) with $\alpha^2 = 2$ and $(\omega_2, \alpha) = 0$. The roots orthogonal to ω_2 is the root system A_7 spanned by α_j for $j \neq 2$. Thus $\text{Stab}_{W(E_8)}(\omega_2)$ is $W(A_7)$. Hence the orbit $W(E_8) \cdot \omega_2$ consists of $|W(E_8)/W(A_7)| = 17280$ elements. Meanwhile if $a^2 = 8$ and $a \in X$, then either $a = 2b$ for some root $b \in X$ or a is primitive. If b is a root and it is not in the lattice \mathbf{Z}^8 , then b equals $\frac{1}{2}(\sum_{i=1}^8 (-1)^{\nu(i)} e_i)$ with $\sum_{i=1}^8 \nu(i)$ even. Hence if a is primitive and $a^2 = 8$, then it is one of the elements of type (i)-(iv). The number of elements of type (i), (ii), (iii) and (iv) are respectively 8960, 128, 1024 and 7168, which totals 17280. This shows that the above 17280 elements are in the single $W(E_8)$ -orbit of ω_2 . Q.E.D.

Lemma 8.13. *Any pair of $a, b \in X$ with $a^2 = b^2 = 4$ and $(a, b) = 3$ is $W(E_8)$ -equivalent.*

Proof. We may assume $a = 2e_8$ by Lemma 8.2. Let F be the set of all b with $b^2 = 4$ and $(2e_8, b) = 3$. Then $F = \{\frac{1}{2}(\sum_{j=1}^7 (-1)^{\nu(j)} e_j + 3e_8); \sum_{j=1}^7 \nu(j) \text{ even}\}$ and $|F| = 64$. Let $b_0 = \frac{1}{2}(\sum_{j=1}^7 e_j + 3e_8)$. Then

we see $W(D_7) = \text{Stab}_{W(E_8)}(2e_8)$ and $W(A_6) = \text{Stab}_{W(E_8)}(2e_8, b_0)$. Thus the orbit $W(D_7) \cdot b_0$ consists of $|W(D_7)/W(A_6)| = 2^6 \cdot 7!/7! = 64$ elements. This proves that $W(D_7)$ acts transitively on F . Q.E.D.

Lemma 8.14. *Any pair of $a, b \in X$ with $a^2 = 4$, $b^2 = 8$ and $(a, b) = 5$ is $W(E_8)$ -equivalent.*

Proof. We may assume $a = 2e_8$ by Lemma 8.2. Let F be the set of all b with $b^2 = 8$ and $(2e_8, b) = 5$. Then $F = \{\frac{1}{2}(\sum_{j=1}^7 (-1)^{\nu(j)} e_j + 35e_8); \sum_{j=1}^7 \nu(j) \text{ even}\}$ and $|F| = 64$. Let $b_0 = \frac{1}{2}(\sum_{j=1}^7 e_j + 5e_8)$. Then we see $W(D_7) = \text{Stab}_{W(E_8)}(2e_8)$ and $W(A_6) = \text{Stab}_{W(E_8)}(2e_8, b_0)$. Thus the orbit $W(D_7) \cdot b_0$ consists of $|W(D_7)/W(A_6)| = 2^6 \cdot 7!/7! = 64$ elements. This proves that $W(D_7)$ acts transitively on F . Q.E.D.

Table 1. The elements of E_8

a^2	$W(E_8)$	number
$a^2 = 2$ (root)	transitive	240
$a^2 = 4$	transitive	2160
$a^2 = 6$	transitive	6720
$a^2 = 8$ (prim)	transitive	17280
$a^2 = 8$ (not prim)	transitive	240

Table 2. The pairs of E_8 elements

a, b	$W(E_8)$
$a^2 = b^2 = 2, ab = 0$	transitive
$a^2 = 4, b^2 = 2, ab = k$ ($k = 0, 1, 2$)	transitive
$a^2 = 4, b^2 = 4, ab = 3$	transitive
$a^2 = 4, b^2 = 8, ab = 5$	transitive
$A_k \subset E_8$ ($2 \leq k \leq 6$)	transitive

Example 8.15. Examples of the pairs in Table 2 are given as follows. The pair $a = e_1 + e_2$, $b = e_3 + e_4$ resp. $a = e_1 + e_2 + e_3 +$

e_4 , $b = e_{4-k} + e_{5-k}$ satisfies $a^2 = b^2 = 2$ and $ab = 0$, resp. $a^2 = 4, b^2 = 2$ and $ab = k$ ($k = 0, 1, 2$).

The pair $a = e_1 + e_2 + e_3 + e_4$, $b = e_2 + e_3 + e_4 + e_5$ satisfies $a^2 = b^2 = 4$ and $ab = 3$, while the pair $a = e_1 + e_2 + e_3 + e_4$, $b = 2e_1 + e_2 + e_3 + e_4 + e_5$ satisfies $a^2 = 4, b^2 = 8$ and $ab = 5$. Similarly an example of A_k for $2 \leq k \leq 6$ is given by the sublattice of E_8 spanned by α_j ($9-k \leq j \leq 8$).

However we note that for $k = 7$ there are two $W(E_8)$ -orbits of sublattices spanned either by (1) α_j ($3 \leq j \leq 8$ and $j = 0$) or by (2) α_j ($4 \leq j \leq 8$ and $j = 0, 2$). See Lemma 10.3.

§9. Decorated diagrams and the Wythoff construction

The purpose of this section is to recall the notions of decorated diagrams of a Dynkin diagram from [MP92], and then the Wythoff construction, due to Coxeter, of Delaunay cells associated with decorated diagrams.

Definition 9.1. A decorated diagram Δ of \tilde{E}_8 is by definition a decomposition of \tilde{E}_8 into two subdiagrams Δ_{Vor} and Δ_{Del} such that

- (i) $|\tilde{E}_8| = |\Delta| = |\Delta_{\text{Vor}}| \cup |\Delta_{\text{Del}}|$,
- (ii) Δ_{Vor} is a subdiagram of \tilde{E}_8 with square nodes \square , crossed unless the square node is connected to Δ_{Del} by an edge,
- (iii) Δ_{Del} is a *connected* subdiagram of \tilde{E}_8 with circle nodes containing the node \odot

where $|\Delta_A|$ is the support of Δ_A , that is, the set of nodes and edges.

Definition 9.2. We define the Voronoi cell $V(q)$ by

$$V(q) = \{ \alpha \in X_{\mathbf{R}}; \|y - \alpha\| \geq \|q - \alpha\| \text{ for any } y \in X \}$$

for $q \in X$. A Voronoi cell V is defined to be a face of $V(q)$ for some $q \in X$.

Let H_0 be the reflection hyperplane of r_0 (see section two), that is, the hyperplane of $X_{\mathbf{R}}$ defined by $H_0 = \{x \in X_{\mathbf{R}}; (\alpha_0, x) = 1\}$. Define F to be the closed domain

$$F = \{x \in X_{\mathbf{R}}; (\alpha_j, x) \geq 0 \ (1 \leq j \leq 8), (\alpha_0, x) \leq 1\}$$

and define F_0 to be the intersection of F and H_0 .

We quote a few basic facts from [MP92, pp. 5095 and section 4].

Lemma 9.3. (i) F is the convex closure of the origin 0 and $\frac{\omega_i}{m_i}$ ($1 \leq i \leq 8$).

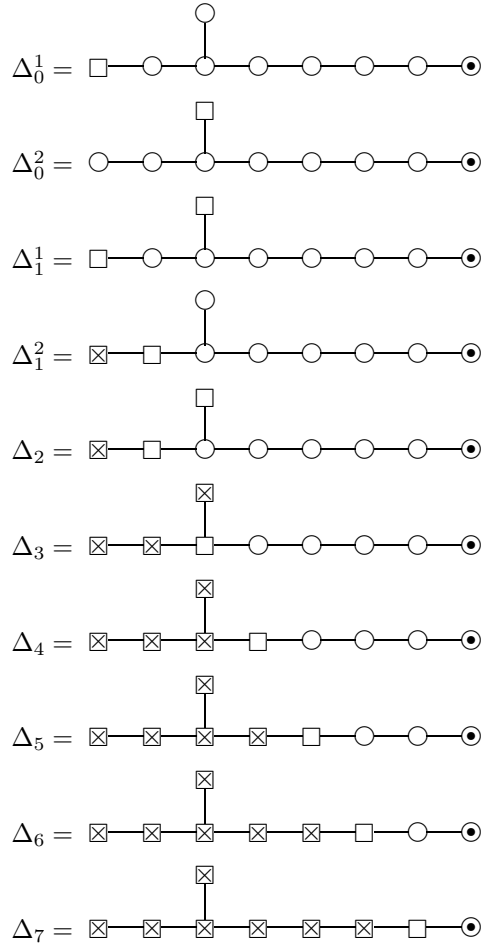

Fig. 1. Decorated diagrams

- (ii) F is a fundamental domain for $W(\tilde{E}_8)$ in the sense that
 - (a) $X_{\mathbf{R}}$ is the union of wF ($w \in W(\tilde{E}_8)$),
 - (b) if $x \in F$ and $w \in W(\tilde{E}_8)$, then $wx \in F \iff wx = x$,
 - (c) if $x \in F$, then $\text{Stab}_{W(\tilde{E}_8)}(x)$ is generated by the reflections with regards to the walls (=one-codimensional faces) of F containing x .
- (iii) The Voronoi cell $V(0)$ is the union of wF ($w \in W(E_8)$).

- (iv) Any Voronoi cell V is the intersection of all $V(q)$ which contains V .

The Wythoff construction of Delaunay cells due to Coxeter is described as follows: Let Δ be a decorated diagram of \tilde{E}_8 . Let S_Δ (resp. S_Δ^*) be the set of nodes of E_8 contained in Δ_{Vor} (resp. $\Delta_{\text{Del}} \setminus \{-\alpha_0\}$). Let $W_{a,\Delta}$ be the reflection subgroup of $W(\tilde{E}_8)$ generated by r_0 and r_α ($\alpha \in S_\Delta^*$). Then V_Δ^0 is defined to be the convex closure of $\frac{\omega_i}{m_i}$ ($\alpha_i \in S_\Delta$) and V_Δ the minimal face of $V(0)$ containing V_Δ^0 . Hence V_Δ is the intersection of all $V(q)$ such that $V_\Delta^0 \subset V(q)$, while $V_\Delta^0 = V_\Delta \cap F_0$. We define D_Δ to be the convex closure of $W_{a,\Delta}(0)$. Since any Delaunay cell is the convex closure of some points of X , this implies that the Delaunay cell D_Δ is the convex closure of all q with $q \in W_{a,\Delta}(0) \cap X$.

For instance, let $\Delta = \Delta_2$. Then Δ_{Vor} is the disjoint union of A_2 and A_1 with square nodes, crossed or uncrossed, while Δ_{Del} is A_6 with the extreme node \odot . Thus $S_\Delta = \{\alpha_1, \alpha_2, \alpha_3\}$ and $S_\Delta^* = \{\alpha_4, \alpha_5, \alpha_6, \alpha_7, \alpha_8\}$.

The following theorem is a summary for the Wythoff construction. See [MP92, Lemma 3-Lemma 5 and (4.29)-(4.31), pp. 5108-5111].

Theorem 9.4. *Let Δ be a decorated diagram of \tilde{E}_8 . Then*

- (i) V_Δ is a Voronoi cell of E_8 , while D_Δ is a Delaunay cell of E_8 dual to V_Δ in the sense that D_Δ is the convex closure of all $a \in X$ such that $\|a - y\| = \min_{b \in X} \|b - y\|$ for any $y \in V_\Delta$.
- (ii) V_Δ is the intersection of all $V(q)$ with $q \in W_{a,\Delta}(0)$, while D_Δ is the convex closure of all q with $q \in W_{a,\Delta}(0)$.
- (iii) If $\Delta = \Delta_k$ or Δ_k^ℓ , then $\dim V_\Delta = k$ and $\dim D_\Delta = 8 - k$.
- (iv) Any Delaunay cell σ of E_8 is a $W(\tilde{E}_8)$ -transform of D_Δ for a decorated diagram Δ of \tilde{E}_8 . If σ contains the origin, then it is a $W(E_8)$ -transform of D_Δ .
- (v) For a subset A of $X_{\mathbf{R}}$, we define

$$\begin{aligned} \text{Stab}_{W(\tilde{E}_8)}(A) &= \{w \in W(\tilde{E}_8); wA \subset A\}, \\ \text{Stab}_{W(E_8)}(A) &= \{w \in W(E_8); wA \subset A\}. \end{aligned}$$

Let W_Δ^1 (resp. W_Δ^2) be the subgroup of $W(\tilde{E}_8)$ generated by r_{α_j} with $\alpha_j \in S_\Delta^*$ (resp. by r_{α_j} with α_j orthogonal to both S_Δ^* and α_0). Then

$$\text{Stab}_{W(\tilde{E}_8)}(D_\Delta) = W_{a,\Delta} \times W_\Delta^2, \quad \text{Stab}_{W(E_8)}(D_\Delta) = W_\Delta^1 \times W_\Delta^2.$$

9.5. Wythoff construction for E_8

In this subsection we give examples of the Wythoff construction for E_8 . Let $h_0 = 2e_8$, $h_j = e_j + e_8$ and $h_{15-j} = -e_j + e_8$ ($1 \leq j \leq 7$). We recall $\omega_1 = 2e_8$ and $\omega_2 = \frac{1}{2}(e_1 + e_2 + \dots + e_7 + 5e_8)$.

9.5.1. $D_{\Delta_0^1} = D(\frac{\omega_1}{2})$. Let $\Delta = \Delta_0^1$. Then we see $\Delta_{\text{Vor}} = \square$ and $V_\Delta = \{\frac{\omega_1}{2}\}$. First we note $r_0(\frac{\omega_1}{2}) = \frac{\omega_1}{2}$, hence $r_0 \in \text{Stab}_{W(\tilde{E}_8)}(\frac{\omega_1}{2})$. The stabilizer subgroup $\text{Stab}_{W(\tilde{E}_8)}(\frac{\omega_1}{2})$ is the reflection subgroup of $W(\tilde{E}_8)$ generated by r_0 and r_α with $(\alpha, \omega_1) = 0$, hence it is generated by r_0 and r_{α_j} ($j = 2, \dots, 8$). We note $W_{a, \Delta_0^1} = \text{Stab}_{W(\tilde{E}_8)}(\frac{\omega_1}{2})$ and $\text{Stab}_{W(E_8)}(\frac{\omega_1}{2}) = W(D_7)$ where $D_7 = E_8 \setminus \{\alpha_1\}$ because it is generated by r_α with roots α orthogonal to ω_1 , hence it is generated by r_{α_j} ($j = 2, \dots, 8$). Since $(\alpha_0, h_j) = 1$ for any $1 \leq j \leq 14$ and $j \neq 7, 8$, we have $r_0(h_j) = h_j$, while $r_0(h_7) = 0$, $r_0(h_8) = h_0$. Let $S = \{0, h_0, h_j, h_{15-j}; 1 \leq j \leq 7\}$. Then $r_0(S) = S$.

As is well known, $W(D_7)$ is a semi-direct product of $(\mathbf{Z}/2\mathbf{Z})^6$ and S_7 . There is a natural surjection $\pi : W(D_7) \rightarrow S_7$. Let $\sigma \in W(D_7)$. Then $\pi(\sigma) \in S_7$. Let $h_j = e_j + e_8$ ($1 \leq j \leq 7$). For $\sigma \in W(D_7)$, $\sigma(e_8) = e_8$, $\sigma(e_j) = (-1)^{\nu(\pi(\sigma)(j))}e_{\pi(\sigma)(j)}$ with $\sum_{j=1}^7 \nu(\pi(\sigma)(j))$ even. For instance, for $3 \leq k \leq 8$ we have $r_{\alpha_k}(e_{k-1}) = e_{k-2}$, $r_{\alpha_k}(e_{k-2}) = e_{k-1}$ and $r_{\alpha_k}(e_j) = e_j$ (otherwise). Therefore $r_{\alpha_k}(S) = S$ for any $2 \leq k \leq 8$. It follows that $W(D_7)(S) = S$. Hence $D(\frac{\omega_1}{2})$ is the convex closure of $W(D_7)(S) = S$. This can be shown directly as we see in Lemma 10.2.

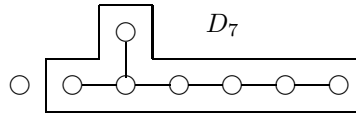

9.5.2. $D_{\Delta_0^2} = D(\frac{\omega_2}{3})$. Let $\Delta = \Delta_0^2$. Then we see $\Delta_{\text{Vor}} = \square$ and $V_\Delta = \{\frac{\omega_2}{3}\}$. The stabilizer group $\text{Stab}_{W(E_8)}(\frac{\omega_2}{3}) = W(A_7)$ because it is generated by r_α with $(\alpha, \omega_2) = 0$, hence it is generated by r_{α_j} ($j = 1, 3, \dots, 8$). We also see $W_{a, \Delta} = \text{Stab}_{W(\tilde{E}_8)}(\frac{\omega_2}{3})$ is generated by r_0 and $\text{Stab}_{W(E_8)}(\frac{\omega_2}{3})$. Let $g_0 = \frac{1}{2}(e_1 + e_2 + \dots + e_8)$ and $S = \{0, g_0, h_j$ ($1 \leq j \leq 7\})$. Then $r_0(g_0) = r_{\alpha_k}(g_0) = g_0$ ($3 \leq k \leq 8$). We also see $r_{\alpha_1}(h_1) = g_0$, $r_{\alpha_1}(g_0) = h_1$ and $r_{\alpha_1}(h_j) = h_j$ (otherwise). Though $\{\alpha_k$ ($3 \leq k \leq 8\}) = A_6$, $W(A_6) = S_7$ acts on the set $\{h_j$ ($1 \leq j \leq 7\})$ as standard permutations. It follows that $D(\frac{\omega_2}{3})$ is the convex closure of $0, h_j$ ($1 \leq j \leq 7$) and g_0 . See Lemma 10.8.

9.5.3. $D_{\Delta_1^k}$. For $\Delta = \Delta_1^k$, $W_{a, \Delta}$ is generated by r_0 and r_{α_j} ($3 \leq j \leq 8$). Hence D_Δ is the convex closure of 0 and h_j ($1 \leq j \leq 7$). For

$\Delta = \Delta_1^2$, $W_{a,\Delta}$ is generated by r_0 and r_{α_j} ($j = 2, 4, 5, \dots, 8$). Hence D_Δ is the convex closure of 0 , h_{14} and h_j ($2 \leq j \leq 7$).

9.5.4. D_{Δ_k} . For a fixed k we let $\Delta = \Delta_k$ ($2 \leq k \leq 7$). Then $W_{a,\Delta}$ is generated by r_0 and r_{α_j} ($j = k + 2, \dots, 8$). Hence D_Δ is the convex closure of 0 and h_j ($k \leq j \leq 7$).

§10. Delaunay cells

By Theorem 9.4 any 8-dimensional Delaunay cell is either $D(\frac{\omega_1}{2})$ or $D(\frac{\omega_2}{3})$ up to $W(\tilde{E}_8)$ where $\frac{\omega_1}{2} = e_8$ and $\frac{\omega_2}{3} = \frac{1}{6}(e_1 + e_2 + \dots + e_7 + 5e_8)$. We recall

$$\text{Stab}_{W(E_8)}(D(\frac{\omega_1}{2})) = W(D_7), \quad \text{Stab}_{W(E_8)}(D(\frac{\omega_2}{3})) = W(A_7).$$

10.1. The Delaunay cell $D(\frac{\omega_1}{2})$

Lemma 10.2. *The Delaunay cell $D(\frac{\omega_1}{2}) = D(e_8)$ is the convex closure of the origin 0 , $\pm e_j + e_8$ ($1 \leq j \leq 7$) and $2e_8$. For $0 < \epsilon < 1$, $D(\frac{\epsilon\omega_1}{2})$ consists of 0 only.*

The polytope $D(\frac{\omega_1}{2})$ is called a 8-cross polytope.

Proof. The cell $D(\frac{\omega_1}{2}) = D(e_8)$ is the convex closure of $a \in X$ with $\|a - e_8\| = 1$. If $a (\neq 0) \in X$ and $\|a - e_8\| = 1$, then writing $a = \sum_{i=1}^8 x_i e_i$ we have $\sum_{i=1}^7 x_i^2 + (x_8 - 1)^2 = 1$. If $x_8 \notin \mathbf{Z}$, then $x_8 = \frac{1}{2}$, or $\frac{3}{2}$ and there are exactly three x_i 's such that $x_i = \frac{1}{2}$ and otherwise $x_j = 0$ for $j \leq 8$. But in either case there is a pair $x_i + x_j \notin \mathbf{Z}$, which is absurd. If $x_8 \in \mathbf{Z}$, then $x_8 = 1$ or 2 . If $x_8 = 1$, then $x_i = 1$ for a unique i and $x_j = 0$ for the other j . The rest is clear. Q.E.D.

Lemma 10.3. *Let $h_0 = 2e_8$, $h_j = e_j + e_8$ and $h_{15-j} = -e_j + e_8$ ($1 \leq j \leq 7$). Let σ_0 (resp. $\sigma_1, \tau_0, \tau_1, \tau_2$) be the convex closure*

$$\begin{aligned} \sigma_0 &= \langle 0, h_1, h_2, \dots, h_7, h_0 \rangle, & \sigma_1 &= \langle 0, h_1, h_2, \dots, h_6, h_8, h_0 \rangle, \\ \tau_0 &= \langle 0, h_1, h_2, \dots, h_7 \rangle, & \tau_1 &= \langle 0, h_1, h_2, \dots, h_6, h_8 \rangle, \\ \tau_2 &= \langle h_0, h_1, h_2, \dots, h_6, h_7 \rangle. \end{aligned}$$

Then

- (i) σ_0 and σ_1 are 8-dimensional. They are not Delaunay cells. The Delaunay cell $D(\frac{\omega_1}{2})$ is the union of 2^6 $W(D_7)$ -transforms of σ_0 and σ_1 .
- (ii) Let $k \leq 7$. Any k -dimensional face of $D(\frac{\omega_1}{2})$ is a $W(D_7)$ -transform of a face of σ_0 . No k -dimensional face of $D(\frac{\omega_1}{2})$ contains both the origin and h_0 . There are exactly $2^{k+1} \cdot \binom{8}{k+1}$ k -dimensional faces of $D(\frac{\omega_1}{2})$.

- (iii) Any k -dimensional face of $D(\frac{\omega_1}{2})$ is $W(\tilde{E}_8)$ -equivalent to D_{Δ_k} for $1 \leq k \leq 6$.
- (iv) Any 7-dimensional face of $D(\frac{\omega_1}{2})$ is $W(\tilde{E}_8)$ -equivalent to either $D_{\Delta_1^1}$ or $D_{\Delta_1^2}$. τ_1 (resp. τ_0) is a Delaunay cell and it is a face of $D(\frac{\omega_1}{2})$, $W(\tilde{E}_8)$ -equivalent to $D_{\Delta_1^1}$ (resp. $D_{\Delta_1^2}$) and $\tau_2 = r_0(\tau_1)$.

Proof. $W(D_7)$ ($= \text{Stab}_{W(E_8)}(\frac{\omega_1}{2})$) is a semi-direct product of $(\mathbf{Z}/2\mathbf{Z})^6$ and the symmetry group S_7 , where S_7 keeps both σ_0 and σ_1 respectively invariant. Let $\pi : W(D_7) \rightarrow S_7$ be the natural surjection. If $\pi(w)$ is the identity, then $w(h_j) = h_j$ or h_{15-j} ($1 \leq j \leq 7$) according as $\nu(j)$ even or odd. Thus if $\pi(w)$ is the identity, we define $\bar{w}(j) := j$ or $15 - j$ according as $\nu(j)$ even or odd. Then we have

$$w \cdot \langle 0, h_1, \dots, h_7, h_0 \rangle = \langle 0, h_{\bar{w}(1)}, \dots, h_{\bar{w}(7)}, h_0 \rangle.$$

For $w \in W(D_7)$, we have $w(e_8) = e_8$, $w(e_j) = (-1)^{\nu(\pi(w)(j))} e_{\pi(w)(j)}$ with $\sum_{j=1}^7 \nu(\pi(w)(j))$ even. See Subsection 9.5. Then we have

$$w \cdot \langle 0, h_1, \dots, h_7, h_0 \rangle = \langle 0, h_{k_1}, \dots, h_{k_7}, h_0 \rangle$$

where $k_j = \pi(w)(j)$ or $15 - \pi(w)(j)$ according as $\nu(\pi(w)(j)) = 0$ or 1 . Note that $\sum_{j=1}^7 \nu(\pi(w)(j))$ is even. Hence there are exactly 2^6 $W(D_7)$ -transforms of σ_0 . Similarly there are exactly 2^6 $W(D_7)$ -transforms of σ_1 . Thus the convex closure $\langle 0, h_{i_1}, \dots, h_{i_7}, h_0 \rangle$ is a $W(D_7)$ -transform of either σ_0 or σ_1 for any $i_k \in \{k, 15 - k\}$.

Next let $z \in D(\frac{\omega_1}{2})$. Since $D(\frac{\omega_1}{2})$ is the convex closure of $0, h_0$ and h_j ($1 \leq j \leq 14$), we write $z = x_0 h_0 + \sum_{j=1}^{14} x_j h_j$ where $x_0 + \sum_{j=1}^{14} x_j \leq 1$ and $x_j \geq 0$ ($0 \leq j \leq 14$). Then we have

$$\begin{aligned} z = & \sum_{x_i \geq x_{15-i}} (x_i - x_{15-i}) h_i + \sum_{x_i < x_{15-i}} (x_i - x_{15-i}) h_{15-i} \\ & + (x_0 + \sum_{i=1}^7 \min(x_i, x_{15-i})) h_0. \end{aligned}$$

The sum of the coefficients of h_i is equal to

$$\sum_{x_i \geq x_{15-i}} (x_i - x_{15-i}) + \sum_{x_i < x_{15-i}} (x_i - x_{15-i}) + x_0 + \sum_{i=1}^7 \min(x_i, x_{15-i})$$

which is equal to $x_0 + \sum_{i=1}^7 \max(x_i, x_{15-i})$. By our assumption on x_i it is not greater than 1. This implies $z \in \langle 0, h_0, h_{i_1}, \dots, h_{i_7} \rangle$ for some $i_k \in \{k, 15 - k\}$ ($1 \leq k \leq 7$). This proves (i).

Next we prove that the convex closure $\langle 0, h_0 \rangle$ of 0 and $h_0 = 2e_8$ intersects the interior of $D(\frac{\omega_1}{2})$. To see this it suffices to prove $e_8 := \frac{h_0}{2}$ is in the interior of $D(\frac{\omega_1}{2})$. In fact, we choose $x_j > 0$ ($0 \leq j \leq 7$) such that $z := \sum_{j=0}^7 x_j = \frac{1}{2}$. Then we have

$$e_8 = \frac{1}{2} \cdot 0 + \frac{1}{2} \sum_{j=1}^7 x_j (h_j + h_{15-j}) + x_0 h_0.$$

Since $0 < x_j < 1$ for any j and $0 < z < 1$, e_8 is in the interior of $D(\frac{\omega_1}{2})$. It follows that the line segment $\langle 0, h_0 \rangle$ intersects the interior of $D(\frac{\omega_1}{2})$. In particular, $\langle 0, h_0 \rangle$ is not a Delaunay cell.

If any lower dimensional face of σ_0 contains both the origin and h_0 , then it is contained in the interior of $D(\frac{\omega_1}{2})$, which is impossible. Therefore no lower dimensional face of σ_0 contains both the origin and h_0 . Hence any lower dimensional face of $D(\frac{\omega_1}{2})$ is a face of the simplex either $w \cdot \langle 0, h_1, \dots, h_7 \rangle$ or $w \cdot \langle h_0, h_1, \dots, h_7 \rangle$ for some $w \in W(D_7)$. Hence any lower dimensional face of $D(\frac{\omega_1}{2})$ is a $W(D_7)$ -transform of a face of τ_0 or τ_2 . If any k -dimensional face of $D(\frac{\omega_1}{2})$ contains the origin, it is $\langle 0, h_{i_1}, \dots, h_{i_k} \rangle$ where $i_j + i_\ell \neq 15$ and $i_j \neq 0$. There are these $2^k \binom{7}{k}$ faces in total. If it contains h_0 , then it is $\langle h_0, h_{i_1}, \dots, h_{i_k} \rangle$ where $i_j + i_\ell \neq 15$ and $i_j \neq 0$. There are these $2^k \binom{7}{k}$ faces in total. If it contain neither the origin nor h_0 , then it is $\langle h_{i_1}, \dots, h_{i_{k+1}} \rangle$ where $i_j + i_\ell \neq 15$ and $i_j \neq 0$. These total $2^{k+1} \binom{7}{k+1}$. Thus we see that there are $2^{k+1} \binom{8}{k+1} = 2^{k+1} \binom{7}{k} + 2^{k+1} \binom{7}{k+1}$ k -dimensional faces of $D(\frac{\omega_1}{2})$. This proves (ii).

Since $\tau_2 = r_0(\tau_1)$, τ_2 is a $W(\tilde{E}_8)$ -transform of τ_1 . By (ii) any k -dimensional face of $D(\frac{\omega_1}{2})$ is a $W(D_7)$ -transform of a face of τ_0 or τ_2 for $k \leq 7$. Therefore it is a $W(\tilde{E}_8)$ -transform of a face of τ_0 or τ_1 . We note that there are exactly the same number of lower-dimensional faces of $D(\frac{\omega_1}{2})$ containing h_0 as those containing the origin. The assertions (iii) and (iv) follow from Subsection 9.5 and the proof of Lemma 8.9 or Corollary 8.10. Q.E.D.

Lemma 10.4. *There are exactly 2160 $W(E_8)$ -transforms of $D(\frac{\omega_1}{2})$ containing the origin. Each $W(E_8)$ -transform is of the form $D(\frac{a}{2})$ for some $a \in X$ with $a^2 = 4$ and vice versa.*

Proof. Any $W(E_8)$ -transform of $D(\frac{\omega_1}{2})$ is of the form $D(w \cdot \frac{\omega_1}{2})$ ($w \in W(E_8)$). Hence the number of $W(E_8)$ -transforms of $D(\frac{\omega_1}{2})$ is equal to $|W(E_8)/W(D_7)| (= 2160)$, which is the number of $a \in X$ with $a^2 = 4$ by Lemma 8.2. Q.E.D.

Proposition 10.5. *There are exactly 135 $W(E_8)$ -transforms of $D(\frac{\omega_1}{2})$ up to translation by X .*

Proof. Those 2160 copies of $D(\frac{\omega_1}{2})$ are of the form $D(\frac{a}{2})$ with $a \in X$ and $a^2 = 4$ by Lemma 10.4. Since $D(\frac{a}{2})$ has 16 vertices, there are 16 translates-by- X of $D(\frac{a}{2})$ containing the origin. Hence there are exactly 135 (= 2160/16) $W(E_8)$ -transforms of $D(\frac{\omega_1}{2})$ up to translation by X .
Q.E.D.

Remark 10.6. $D(\frac{a'}{2})$ is a translate of $D(\frac{a}{2})$ by X if and only if $a - a' = 2x$ for some root x . By Lemma 8.2, we assume $a = 2e_8$. By Lemma 8.2 we see readily $a' = \pm 2e_k$. It follows that there are precisely 16 translates $D(\frac{a'}{2})$ by X of $D(\frac{2e_8}{2})$.

10.7. The Delaunay cell $D(\frac{\omega_2}{3})$

Lemma 10.8. *The Delaunay cell $D(\frac{\omega_2}{3})$ is the convex closure of the origin 0, $h_j = e_j + e_8$ ($1 \leq j \leq 7$) and $g_0 := \frac{1}{2}(e_1 + e_2 + \cdots + e_8)$.*

Proof. $D(\frac{\omega_2}{3})$ is the convex closure of $a \in X$ with $\|a - \frac{\omega_2}{3}\|^2 = \|\frac{\omega_2}{3}\|^2 = \frac{8}{9}$. Let $a = \sum_{j=1}^8 x_j e_j$ and suppose $\|a - \frac{\omega_2}{3}\|^2 = \frac{8}{9}$. If $x_8 \in \mathbf{Z}$, then $x_8 = 0$ or 1. If $x_8 = 0$, then $a = 0$. If $x_8 = 1$, then $a = e_j + e_8$ for some $j \leq 7$. If x_8 is not an integer, then $x_8 = \frac{1}{2}$ or $\frac{3}{2}$ and $x_j = \frac{1}{2}$ for $1 \leq j \leq 7$. If $x_8 = \frac{1}{2}$, then $a = g_0$. If $x_8 = \frac{3}{2}$, then no $a \in X$ is possible.
Q.E.D.

Corollary 10.9. *There are exactly $\binom{8}{k}$ k -dimensional faces of $D(\frac{\omega_2}{3})$.*

Proof. Clear because the 8-dimensional cell $D(\frac{\omega_2}{3})$ has only nine vertices.
Q.E.D.

We call $a \in X$ *primitive* if a is not an integral multiple of any element of X .

Lemma 10.10. *There are exactly 17280 $W(E_8)$ -transforms of $D(\frac{\omega_2}{3})$ containing the origin. Each $W(E_8)$ -transform is of the form $D(\frac{a}{3})$ for some primitive $a \in X$ with $a^2 = 8$ and vice versa.*

Proof. Any $W(E_8)$ -transform of $D(\frac{\omega_1}{2})$ is of the form $D(w \cdot \frac{\omega_2}{3})$ ($w \in W(E_8)$), hence of the form $D(\frac{a}{3})$ with a primitive and $a^2 = 8$. Therefore the number of $W(E_8)$ -transforms of $D(\frac{\omega_2}{3})$ is equal to $|W(E_8)/W(A_7)| = 17280$, the number of $a \in X$ with $a^2 = 8$ by Lemma 8.12.
Q.E.D.

Proposition 10.11. *There are exactly 1920 $W(E_8)$ -transforms of $D(\frac{\omega_2}{3})$ up to translation by X .*

Proof. Those 17280 copies are of the form $D(\frac{a}{3})$ with $a \in X$ and $a^2 = 8$. Each copy has 9 vertices, hence there are exactly 1920 (= 17280/9) $W(E_8)$ -transforms of $D(\frac{\omega_2}{3})$ up to translation by X . Q.E.D.

Remark 10.12. Since any vertex of $D(\frac{\omega_2}{3})$ other than 0 is a root, $D(\frac{a'}{3})$ is a translate of $D(\frac{a}{3})$ by X if and only if $a - a' = 3x$ for some root $x \in X$ or $x = 0$. If $a - a' = 3x \neq 0$, then $2aa' = -9x^2 + a^2 + (a')^2 = -2$. Hence $aa' = -1$. Therefore x is a root with $ax = 3$. Conversely if x is a root with $ax = 3$, then $a' = a - 3x$ gives a translate $D(\frac{a'}{3})$ of $D(\frac{a}{3})$. By Lemma 8.12, we may assume $a = e_1 + e_2 + e_3 + e_4 + 2e_8$. Suppose x is a root with $ax = 3$. Then by Lemma 8.12, $x = e_k + e_8$ ($1 \leq k \leq 4$) or $x = \frac{1}{2}(e_1 + e_2 + e_3 + e_4 \pm e_5 \pm e_6 \pm e_7 + e_8)$. Hence there are precisely 9 (= 1 + 4 + 4) X -translates $D(\frac{a'}{3})$ of $D(\frac{a}{3})$.

Thus we see the following table by applying Lemma 10.3 and Corollary 10.9.

Table 3. The number of faces of 8-dim Delaunay cells

d	7	6	5	4	3	2	1	0
$D(\frac{\omega_1}{2})$	256	1024	1792	1792	1120	448	112	16
$D(\frac{\omega_2}{3})$	9	36	84	126	126	84	36	9

10.13. Adjacency of 8-dimensional Delaunay cells

Lemma 10.14. *No pair of $a, b \in X$ with $a^2 = 4$, $b^2 = 2$ and $(a, b) = 0$ belong to the same 8-dimensional Delaunay cells.*

Proof. By Lemma 8.5 they are equivalent to $a = 2e_8$ and $b = -e_6 + e_7$. They could belong to one of the Delaunay cells $D(\frac{a}{2})$ with $a^2 = 4$. Since h_0 is the unique vertex of $D(\frac{\omega_1}{2})$ with $h_0^2 = 4$, there are no vertex z ($\neq 0$) of $D(\frac{\omega_1}{2})$ with $(h_0, z) = 0$. This proves the lemma. Q.E.D.

Proposition 10.15. *Let a, a', b and $b' \in X$ with $a^2 = (a')^2 = 4$ and $b^2 = (b')^2 = 8$.*

- (i) $D(\frac{a}{2})$ and $D(\frac{a'}{2})$ are adjacent iff $(a, a') = 3$.
- (ii) $D(\frac{a}{2})$ and $D(\frac{b}{3})$ are adjacent iff $(a, b) = 5$.
- (iii) $D(\frac{b}{3})$ and $D(\frac{b'}{3})$ are not adjacent.

Proof. By Theorem 9.4 there are precisely two $W(\tilde{E}_8)$ equivalence classes of 7-dimensional Delaunay cells. By Lemma 10.3, each class is

represented by either $\langle 0, h_1, \dots, h_7 \rangle$ or $\langle 0, h_1, \dots, h_6, h_8 \rangle$. In the first case, the face $\langle 0, h_1, \dots, h_7 \rangle$ is a common face of $D(\frac{\omega_1}{2})$ and $D(\frac{\omega_2}{3})$ by Lemma 10.2 and Lemma 10.8. We have $\omega_1\omega_2 = 5$. Any pair a and b with $a^2 = 4$, $b^2 = 8$ and $(a, b) = 5$ is unique up to $W(E_8)$ by Lemma 8.14. This proves (ii).

In the second case let $\alpha = \frac{1}{2}(e_7 + e_8 - (e_1 + \dots + e_6))$. Then since $(\alpha, h_j) = (\alpha, h_8) = 0$ ($1 \leq j \leq 6$), r_α keeps the face $\tau_1 = \langle 0, h_1, \dots, h_6, h_8 \rangle$ invariant. Therefore τ_1 is a common face of $D(\frac{\omega_1}{2})$ and $r_\alpha D(\frac{\omega_1}{2}) = D(\frac{\omega}{2})$ where $\omega = r_\alpha(\omega_1) = \frac{1}{2}(e_1 + \dots + e_6 - e_7 + 3e_8)$. We have $\omega_1\omega = 3$. Any pair a and b with $a^2 = b^2 = 4$ and $ab = 3$ is unique up to $W(E_8)$ by Lemma 8.14. This proves (i).

There are 17280 copies of $D(\frac{\omega_2}{3})$. Hence there are $8 \cdot 17280 = 138240$ 7-dimensional faces of copies of $D(\frac{\omega_2}{3})$. Meanwhile there are 2160 copies of $D(\frac{\omega_1}{2})$, hence there are $128 \cdot 2160 = 276480$ 7-dimensional faces of copies of $D(\frac{\omega_2}{3})$, the half of which are faces of copies of $D(\frac{\omega_1}{2})$ and the other half of which are faces of copies of $D(\frac{\omega_2}{3})$. It follows that there are no common faces of $D(\frac{b}{3})$ and $D(\frac{b'}{3})$. This proves (iii). Q.E.D.

- Corollary 10.16.** (i) *Any 8-dimensional cell adjacent to $D(\frac{\omega_1}{2})$ is either $D(wr_{\alpha_1}\frac{\omega_1}{2})$ or $D(w\frac{\omega_2}{3})$ ($w \in \text{Stab}_{W(E_8)}(\omega_1) = W(D_7)$). There are exactly 128 copies of $D(\frac{\omega_1}{2})$ adjacent to $D(\frac{\omega_1}{2})$ and exactly 128 copies of $D(\frac{\omega_2}{3})$ adjacent to $D(\frac{\omega_1}{2})$.*
- (ii) *Any 8-dimensional cell adjacent to $D(\frac{\omega_2}{3})$ is $D(w\frac{\omega_1}{2})$ where $w \in \text{Stab}_{W(E_8)}(\omega_2) = W(A_7)$. There are exactly 8 copies of $D(\frac{\omega_1}{2})$ adjacent to $D(\frac{\omega_2}{3})$.*

Proof. By Lemma 10.15, $D(\frac{\omega_1}{2})$ is adjacent to $D(\frac{\omega}{2})$ and $D(\frac{\omega_2}{3})$ where $\omega = \frac{1}{2}(e_1 + \dots + e_6 - e_7 + 3e_8) = r_\alpha(\omega_1)$. Therefore any 8-dimensional Delaunay cell adjacent to $D(\frac{\omega_1}{2})$ is either $D(w \cdot \frac{\omega}{2})$ or $D(w \cdot \frac{\omega_2}{3})$ for any $w \in \text{Stab}_{W(E_8)}(\omega_1) = W(D_7)$. We note

$$\alpha = \frac{1}{2}(e_7 + e_8 - (e_1 + \dots + e_6)) = r_{\alpha_8}r_{\alpha_7} \cdots r_{\alpha_3}(\alpha_1).$$

Let $w_0 = r_{\alpha_8}r_{\alpha_7} \cdots r_{\alpha_3} \in W(D_7)$. Then $r_\alpha = w_0 \cdot r_{\alpha_1} \cdot w_0$. Hence

$$D(\frac{\omega}{2}) = w_0 \cdot r_{\alpha_1} \cdot w_0(D(\frac{\omega_1}{2})) = w_0 \cdot r_{\alpha_1}(D(\frac{\omega_1}{2}))$$

Hence any 8-dimensional Delaunay cell adjacent to $D(\frac{\omega_1}{2})$ is either $D(w \cdot r_{\alpha_1}\frac{\omega_1}{2})$ or $D(w\frac{\omega_2}{3})$ for any $w \in \text{Stab}_{W(E_8)}(\omega_1) = W(D_7)$. The number of $D(w \cdot r_{\alpha_1}\frac{\omega_1}{2})$ adjacent to $D(\frac{\omega_1}{2})$ is equal to the number of 7-dimensional Delaunay faces of $D(\frac{\omega_1}{2})$, $W(E_8)$ -equivalent to τ_1 by the proof of Proposition 10.15, hence it is equal to $2^8 \cdot \binom{8}{7}/8 = 128$ where 8

in the denominator is the number of vertices of τ_1 . Similarly the number of $D(w\frac{\omega_2}{3})$ adjacent to $D(\frac{\omega_1}{2})$ is equal to $2^8 \cdot \binom{8}{7}/8 = 128$. The assertion (ii) is clear. Q.E.D.

10.17. Inclusion relation of Delaunay cells

Proposition 10.18. *Let $a, b \in X$ with $a^2 = 4, b^2 = 8$ and let $\{a_k, a_{k+1}, \dots, a_7\}$ ($1 \leq k \leq 7$) be a set of roots such that $a_i^2 = 2$ and $(a_i, a_j) = 1$ for any $i \neq j$. Let D be the convex closure of the origin and a_k, \dots, a_7 . Then D is a Delaunay cell and*

- (i) $D \subset D(\frac{a}{2})$ iff $(a_i, a) = 2$ for any i .
- (ii) $D \subset D(\frac{b}{3})$ iff $(a_i, b) = 3$ for any i .

Proof. Since D is the convex closure of 0 and $a_i, D \subset D(\frac{a}{2})$ iff 0 and a_i are closest to the hole $\frac{a}{2}$. Hence $\|\frac{a}{2}\| = \|a_i - \frac{a}{2}\|$. This proves (i). The proof of (ii) is similar. Q.E.D.

Corollary 10.19. *Let D be the convex closure of the origin and a_k, \dots, a_7 as in Proposition 10.18. Then D is the intersection of $D(\frac{a}{2})$ and $D(\frac{b}{3})$ for all a and b such that $a^2 = 4$ and $(a_i, a) = 2$ for any i , or $b^2 = 6$ and $(a_i, b) = 3$ for any i respectively.*

Proof. Since any Delaunay cell is the intersection of all maximal dimensional Delaunay cells containing it, Corollary follows from Proposition 10.18. Q.E.D.

Corollary 10.20. *For a Delaunay cell D of dimension $8-k$ given in 10.18, there are exactly the following number given in Table 4 of $D(\frac{a}{2})$'s and $D(\frac{b}{3})$'s containing D :*

Table 4. The number of 8-dim. cells containing a fixed Delaunay cell

k	7	6	5	4	3	2	Δ_1^1	Δ_1^2
$D(\frac{a}{2})$	126	27	10	5	3	2	1	2
$D(\frac{b}{3})$	576	72	16	5	2	1	1	0
total	702	99	26	10	5	3	2	2

Proof. Suppose $k \geq 2$. Then by Lemma 8.9 we may assume $a_i = e_i + e_8$ ($k \leq i \leq 7$). Let $D(k)$ be the convex closure of $a_i = e_i + e_8$ ($k \leq i \leq 7$). In view of Lemma 10.18 $D(k) \subset D(\frac{a}{2})$ iff $(a_i, a) = 2$ for any i . Suppose $k = 7$. Then $D(7) \subset D(\frac{2e_8}{2})$. We see $\text{Stab}_W(E_8)(e_7 + e_8) = W(E_7)$

and $\text{Stab}_{W(E_8)}(e_7 + e_8, 2e_8) = W(D_6)$. Thus in view of Lemma 8.8 the number of $D(\frac{a}{2})$ with $D(7) \subset D(\frac{a}{2})$ is equal to $|W(E_7)|/|W(D_6)| = 2^{10} \cdot 3 \cdot 5 \cdot 7/2^9 \cdot 3^2 \cdot 5 = 126$. Similarly If $k = 6$, then $D(6) \subset D(\frac{a}{2})$ iff $a = 2e_8, \pm e_i + e_6 + e_7 + e_8$, or $\frac{1}{2}(\sum_{j=1}^5 \pm e_j + e_6 + e_7 + 3e_8)$. Hence there are exactly $1 + 10 + 2^4 = 27$ cells $D(\frac{a}{2})$ which contain $D(6)$. This is checked by computing $|W(E_6)|/|W(D_5)| = 27$. If $k = 5$, then $D(5) \subset D(\frac{a}{2})$ iff $a = 2e_8, e_5 + e_6 + e_7 + e_8$, or $\frac{1}{2}(\sum_{j=1}^4 \pm e_j + e_5 + e_6 + e_7 + 3e_8)$. Hence there are exactly $1 + 1 + 8 = 10$ cells $D(\frac{a}{2})$ which contain $D(5)$. This is checked by computing $|W(D_5)|/|W(D_4)| = 10$. If $2 \leq k \leq 4$, then $D(k) \subset D(\frac{a}{2})$ iff $a = 2e_8$ or $\frac{1}{2}(\sum_{j=1}^{k-1} \pm e_j + e_k + \cdots + e_7 + 3e_8)$. Hence there are exactly $1 + 2^{k-2}$ cells $D(\frac{a}{2})$ which contain $D(k)$. This is checked by computing $|W(A_4)|/|W(A_3)| = 5$, $|W(A_1) \times W(A_2)|/|W(A_1) \times W(A_1)| = 3$ and $|W(A_1)| = 2$. If $k = 1$, then there is a unique $D(\frac{a}{2})$ which contain D .

Next we consider $D(\frac{b}{3})$. Let $G(k) = \text{Stab}_{W(E_8)}(e_k + e_8, \cdots, e_7 + e_8)$ and $H(k) = \text{Stab}_{W(E_8)}(\omega_2) \cap G(k)$. Then though it is nontrivial, by explicit computation we see the number of $D(\frac{b}{3})$ containing $D(k)$ is equal to $|G(k)|/|H(k)|$. We see $G(k) = W(E_7), W(E_6), W(D_5), W(A_4), W(A_1 \times A_2)$ and $W(A_1)$, while $H(k) = W(A_{k-1})$ for any k . Hence the number of $D(\frac{b}{3})$ containing $D(k)$ is equal to 576, 72, 16, 5, 2 and 1 respectively. The case $k = 1$ is clear from Proposition 10.15. Q.E.D.

§11. A PSQAS associated with E_8

Now we return to the situation in the section three. Let $B(x, y)$ be the bilinear form on the lattice X in Definition 3.1. We assume that (X, B) is the E_8 -lattice. Let (Q, L) be the flat projective R -scheme in Theorem 3.3, (Q_0, L_0) the closed fibre of it. Let $R(c)$ be the coordinate ring of an affine chart $U(c)$ ($c \in X/Y$) of Q_0 in Definition 3.6. The purpose of this section is to show that there are actually nilpotent elements in $R(0)$. For this purpose we determine the function v on X in Definition 2.9 explicitly.

Let D be a convex polytope containing the origin, $C(0, D)$ the cone over \mathbf{R}_0 generated by $D \cap X$, and $\text{Semi}(0, D)$ the cone over \mathbf{Z}_0 of $D \cap X$. Recall (and define)

$$\begin{aligned} h_0 &= 2e_8, \quad h_j = e_j + e_8, \quad h_{15-j} = -e_j + e_8 \quad (1 \leq j \leq 7) \\ g_0 &= \frac{1}{2}(e_1 + e_2 + \cdots + e_8), \quad g_\infty = g_0 + h_0 = \frac{1}{2}\left(\sum_{j=1}^7 e_j + 5e_8\right), \\ \sigma_0 &= \langle 0, h_1, h_2, \cdots, h_7, h_0 \rangle, \quad \sigma_1 = \langle 0, h_1, h_2, \cdots, h_6, h_8, h_0 \rangle. \end{aligned}$$

Lemma 11.1. *Let $h(\sigma_0) = \frac{1}{2}(\sum_{j=0}^7 h_j)$ and $h(\sigma_1) = \frac{1}{2}(\sum_{j=1}^6 h_j + h_8)$. Then*

(i) *we have*

$$\begin{aligned} \text{Semi}(0, \sigma_0) &= \mathbf{Z}_0 h_1 + \cdots + \mathbf{Z}_0 h_6 + \mathbf{Z}_0 h_7 + \mathbf{Z}_0 h_0, \\ \text{Semi}(0, \sigma_1) &= \mathbf{Z}_0 h_1 + \cdots + \mathbf{Z}_0 h_6 + \mathbf{Z}_0 h_8 + \mathbf{Z}_0 h_0. \end{aligned}$$

- (ii) $h(\sigma_k) \in C(0, \sigma_k) \cap X$ but $h(\sigma_k) \notin \text{Semi}(0, \sigma_k)$ ($k = 0, 1$).
- (iii) $C(0, D(\frac{\omega_1}{2})) \cap X$ is the union of all $C(0, w \cdot \sigma_0) \cap X$ and $C(0, w \cdot \sigma_1) \cap X$ where w ranges over $W(D_7)$.
- (iv) $C(0, \sigma_0) \cap X$ is generated by $\text{Semi}(0, \sigma_0)$ and $h(\sigma_0)$. It is the disjoint union of $\text{Semi}(0, \sigma_0)$ and $h(\sigma_0) + \text{Semi}(0, \sigma_0)$:

$$C(0, \sigma_0) \cap X = \text{Semi}(0, \sigma_0) \sqcup (h(\sigma_0) + \text{Semi}(0, \sigma_0)).$$

- (v) $C(0, \sigma_1) \cap X$ is generated by $\text{Semi}(0, \sigma_1)$ and $h(\sigma_1)$. It is the disjoint union of $\text{Semi}(0, \sigma_1)$ and $h(\sigma_1) + \text{Semi}(0, \sigma_1)$:

$$C(0, \sigma_1) \cap X = \text{Semi}(0, \sigma_1) \sqcup (h(\sigma_1) + \text{Semi}(0, \sigma_1)).$$

- (vi) $C(0, w \cdot \sigma_k) \cap X = w \cdot (C(0, \sigma_k) \cap X)$ where $k = 0, 1$ and $w \in W(D_7)$.

Proof. By Lemma 10.2, $\sigma_0 \cap X \subset D(\frac{\omega_1}{2}) \cap X = \{0, h_j \ (0 \leq j \leq 14)\}$ and $\sigma_1 \cap X \subset D(\frac{\omega_1}{2}) \cap X$, which implies (i). Since $h(\sigma_0) = g_0 + 2h_0 \in X$, (ii) is clear for σ_0 because $h_j \ (0 \leq j \leq 7)$ are linearly independent and $\sigma_0 \cap X = \{0, h_j \ (0 \leq j \leq 7)\}$. Since $h(\sigma_1) = g_0 + h_0 + h_8 \in X$ (ii) is also clear for σ_1 . (iii) follows from the fact that $D(\frac{\omega_1}{2})$ is the union of $w \cdot \sigma_0$ and $w \cdot \sigma_1$ ($w \in W(D_7)$). See Lemma 10.3 (i). Next we prove (iii). Let $x \in C(0, \sigma_0) \cap X$. Then we write $x = \sum_{j=0}^7 a_j h_j$ with $a_j \geq 0$. If $a_j = 0$ for any $j \geq 1$, then $x = a_0 h_0$, $a_0 \in \mathbf{Z}_+$. Hence $x \in \text{Semi}(0, \sigma_0)$. So we may assume $a_1 > 0$ (by transforming x by S_7 if necessary). If $a_1 \in \mathbf{Z}_+$, then $x \in \text{Semi}(0, \sigma_0)$. So we assume a_1 is not an integer, hence $a_1 \equiv \frac{1}{2} \pmod{\mathbf{Z}}$. Hence $a_j \equiv \frac{1}{2} \pmod{\mathbf{Z}}$ for any $j \geq 2$. Since $x \in X$, $\sum_{j=0}^7 a_j$ is integral, hence $a_0 \equiv \frac{1}{2} \pmod{\mathbf{Z}}$. Hence $a_j \geq \frac{1}{2}$ for any $j \geq 0$. Let $z = x - h(\sigma_0)$. Since $h(\sigma_0) \in X$, we have $z \in C(0, \sigma_0) \cap X$ and $z = \sum_{j=0}^7 b_j h_j$ for some $b_j \in \mathbf{Z}_0$, namely, $z \in \text{Semi}(0, \sigma_0)$. This proves (iv).

Next we prove (v). Let $x \in C(0, \sigma_0) \cap X$. Then we write $x = \sum_{j=0}^6 a_j h_j + a_8 h_8$ with $a_j \geq 0$. If $a_j = 0$ for any $j \geq 1$, then $x = a_0 h_0$, $a_0 \in \mathbf{Z}_+$. Hence $x \in \text{Semi}(0, \sigma_0)$. So we may assume $a_1 > 0$ (by transforming x by $\text{Stab}_{W(D_7)}(\sigma_1)$ if necessary). If $a_1 \in \mathbf{Z}_+$, then $x \in \text{Semi}(0, \sigma_0)$. So we assume a_1 is not an integer, hence $a_1 \equiv \frac{1}{2}$

mod \mathbf{Z} . Hence $a_j \equiv \frac{1}{2} \pmod{\mathbf{Z}}$ for any $j \geq 2$. Since $x \in X$, $\sum_{j=0}^6 a_j$ is integral, hence a_0 is integral. Let $z = x - h(\sigma_1)$. Since $h(\sigma_1) \in X$, we have $z \in C(0, \sigma_1) \cap X$ and $z = a_0 h_0 + \sum_{j=1}^6 b_j h_j + b_8 h_8$ for some $b_j \in \mathbf{Z}_0$. Since $a_0 \in \mathbf{Z}_0$, we have $z \in \text{Semi}(0, \sigma_0)$. This proves (v). The remaining assertions are clear. Q.E.D.

Lemma 11.2. *Let $g_\infty = g_0 + h_0 = \frac{1}{2}(\sum_{j=1}^7 e_j + 5e_8)$. Then $C(0, D(\frac{\omega_2}{3})) \cap X$ is generated by $h_1, h_2, \dots, h_7, g_0$ and g_∞ . It is the disjoint union of $\text{Semi}(0, D(\frac{\omega_2}{3}))$, $g_\infty + \text{Semi}(0, D(\frac{\omega_2}{3}))$ and $2g_\infty + \text{Semi}(0, D(\frac{\omega_2}{3}))$:*

$$C(0, D(\frac{\omega_2}{3})) \cap X = \sqcup_{k=0,1,2} (kg_\infty + \text{Semi}(0, D(\frac{\omega_2}{3})))$$

where we note that g_∞ does not belong to $D(\frac{\omega_2}{3}) \cap X$.

Proof. First we note that $3g_\infty = h_1 + h_2 + \dots + h_7 + g_0$ and hence $g_\infty \in C(0, D(\frac{\omega_2}{3})) \cap X$. Let $C_0 = \mathbf{Z}_0 h_1 + \dots + \mathbf{Z}_0 h_7 + \mathbf{Z}_0 g_0$. Then $C_0 = \text{Semi}(0, D(\frac{\omega_2}{3}))$. Suppose $x \in C(0, D(\frac{\omega_2}{3})) \cap X$. Then we write

$$x = \sum_{j=1}^7 x_j h_j + x_0 g_0 = \sum_{j=1}^7 (x_j + \frac{x_0}{2}) e_j + (\sum_{j=1}^7 x_j + \frac{x_0}{2}) e_8$$

where $x_j \geq 0$, $x_j - x_j \in \mathbf{Z}$, $2x_1 + x_0 \in \mathbf{Z}$ and $7x_1 + 2x_0 \in \mathbf{Z}$. It follows that $3x_0 \in \mathbf{Z}$ and $x_k \equiv x_0 \pmod{\mathbf{Z}}$ for any $1 \leq k \leq 7$. Suppose $x_0 \in \mathbf{Z}$. Then any $x_j \in \mathbf{Z}$ and $x \in C_0$. Suppose next $x_0 \equiv \frac{1}{3} \pmod{\mathbf{Z}}$. Then let $z_j = x_j - \frac{1}{3}$ and $z = x - g_\infty$. Since $x_j \geq 0$ and $x_j \equiv \frac{1}{3} \pmod{\mathbf{Z}}$, we have $z_j \in \mathbf{Z}_0$. It follows $z \in C_0$. Suppose finally $x_0 \equiv \frac{2}{3} \pmod{\mathbf{Z}}$. Then $z = x - 2g_\infty \in C_0$. This proves the lemma. Q.E.D.

Lemma 11.3. *Let $D = D(\frac{\omega_1}{2})$ and let $\alpha(D) = \frac{\omega_1}{2} = e_8$ be the hole of D . Then*

$$v(x) = \begin{cases} (x, \alpha(D)) & \text{if } x \in \text{Semi}(0, D) \\ (x - h(\sigma_0), \alpha(D)) + 5 & \text{if } x \in h(\sigma_0) + \text{Semi}(0, \sigma_0) \\ (x - h(\sigma_1), \alpha(D)) + 4 & \text{if } x \in h(\sigma_1) + \text{Semi}(0, \sigma_1) \\ (x - w \cdot h(\sigma_0), \alpha(D)) + 5 & \text{if } x \in w \cdot h(\sigma_0) + \text{Semi}(0, w \cdot \sigma_0) \\ (x - w \cdot h(\sigma_1), \alpha(D)) + 4 & \text{if } x \in w \cdot h(\sigma_1) + \text{Semi}(0, w \cdot \sigma_1) \end{cases}$$

where $w \in W(D_7) = \text{Stab}_{W(E_8)}(\frac{\omega_1}{2})$.

Proof. If $x \in \text{Semi}(0, D)$, then $v(x) = (x, \alpha(D))$ by Lemma 2.10. Next suppose $x = h(\sigma_0)$. Then $h(\sigma_0) = g_0 + h_0 + h_0$ where $g_0 = \frac{1}{2}(\sum_{j=1}^8 e_j)$. Therefore $v(h(\sigma_0)) \leq \frac{1}{2}(g_0^2 + 2h_0^2) = 5$.

Meanwhile $(2h(\sigma_0), \alpha(D)) = (\sum_{j=0}^7 h_j, e_8) = 9$, whence $v(h(\sigma_0)) \geq 5$ by Lemma 2.10 and Lemma 11.1. This proves $v(h(\sigma_0)) = 5$. This also proves the second equality for $x = h(\sigma_0)$. Next suppose $x = h(\sigma_0) + z$ for some $z \in \text{Semi}(0, \sigma_0)$. Then $v(x) \leq v(h(\sigma_0)) + v(z) = v(z) + 5$. Meanwhile $v(x) \geq (h(\sigma_0) + z, \alpha(D)) = \frac{9}{2} + v(z)$. This proves the second equality for $x = h(\sigma_0) + z, z \in \text{Semi}(0, \sigma_0)$.

We see $h(\sigma_1) = g_0 + h_0 + h_8$ and $v(h(\sigma_1)) \leq 4$. On the other hand $(2h(\sigma_1), \alpha(D)) = (\sum_{j=1}^6 h_j + h_8, \alpha(D)) = (\sum_{j=1}^6 h_j + h_8, e_8) = 7$, whence $v(h(\sigma_1)) \geq 4$ by Lemma 2.10 and Lemma 11.1. This proves $v(h(\sigma_1)) = 4$. This also proves the third equality for $x \in h(\sigma_1) + \text{Semi}(0, \sigma_1)$. The remaining assertions are clear. Q.E.D.

Lemma 11.4. *Let $D = D(\frac{\omega_2}{3})$ and $\alpha(D) = \frac{\omega_2}{3}$ the hole of D . Then $v(x + kg_\infty) = (x, \alpha(D)) + 3k$ for $k = 0, 1, 2$ and $x \in \text{Semi}(0, D)$.*

Proof. Let $a_\infty = \frac{1}{2}(e_1 + e_2 + e_3 + e_4 - e_5 - e_6 + e_7 + e_8)$. Then $g_\infty = h_5 + h_6 + a_\infty$ and $v(g_\infty) \leq 3$. Since $(3g_\infty, \alpha(D)) = 8$, we have $v(g_\infty) \geq (g_\infty, \alpha(D)) = \frac{8}{3}$. This proves $v(g_\infty) = 3$. This also proves the lemma in the case $k = 1$. Similarly we see $v(g_\infty) \leq 6$ while $v(2g_\infty) \geq (2g_\infty, \alpha(D)) = \frac{16}{3}$. Since $v(2g_\infty)$ is an integer, we have $v(2g_\infty) = 6$. This also proves the lemma in the case $k = 2$. Q.E.D.

Theorem 11.5. *Let $D \in \text{Del}(0)$ and $\alpha(D)$ its hole. For $x \in C(0, D) \cap X$ we have*

$$v(x) = \lceil (x, \alpha(D)) \rceil := -\lceil -(x, \alpha(D)) \rceil, \text{ the round-up of } (x, \alpha(D)).$$

In particular, $x \in \text{Semi}(0, D)$ iff $(x, \alpha(D)) \in \mathbf{Z}$.

Proof. We may assume D is 8-dimensional. If $D = D(\frac{\omega_1}{2})$, then

$$v(x) = \begin{cases} (x, \alpha(D)) & \text{if } x \in \text{Semi}(0, D) \\ (x, \alpha(D)) + \frac{1}{2} & \text{(otherwise).} \end{cases}$$

This also proves the corollary when $D \in \text{Del}(0)$ is an 8-dimensional Delaunay cell $W(E_8)$ -equivalent to $D = D(\frac{\omega_1}{2})$. If $D = D(\frac{\omega_2}{3})$, then

$$v(x) = \begin{cases} (x, \alpha(D)) & \text{if } x \in \text{Semi}(0, D) \\ (x, \alpha(D)) + \frac{1}{3} & \text{if } x \in g_\infty + \text{Semi}(0, D) \\ (x, \alpha(D)) + \frac{2}{3} & \text{if } x \in 2g_\infty + \text{Semi}(0, D). \end{cases}$$

This also proves the corollary when $D \in \text{Del}(0)$ is an 8-dimensional Delaunay cell $W(E_8)$ -equivalent to $D = D(\frac{\omega_2}{3})$. The above proof also proves the second assertion of the corollary. This completes the proof. Q.E.D.

Theorem 11.6. *Let Q_0 be the closed fibre of Q and $\text{rad}(O_{0,Q_0})$ the radical of the algebra O_{0,Q_0} . Then $\text{rad}(O_{0,Q_0})$ is generated over $k(0)$ by the monomials $\bar{\xi}(x)$ with $v(x) > (x, \alpha(D))$ and $x \in C(0, D) \cap X$ for some $D \in \text{Del}(0)$. It is also generated by $\bar{\xi}(x)$ with $x \in C(0, D) \cap X$ and $(x, \alpha(D))$ not integral.*

Proof. Let $z \in O_{0,Q_0}$. We write z as a $k(0)$ -linear irredundant combination of $\bar{\xi}(x)$, ($x \in X$). Then if $z \in O_{0,Q_0}$ is nilpotent, each monomial component $\bar{\xi}(x)$ of z is also nilpotent because the algebra O_{0,Q_0} is X -graded. The monomial $\bar{\xi}(x) = q^{v(x)}w^x \in \text{rad}(O_{0,Q_0})$ iff $q^{nv(x)}w^{nx} = 0$ for some positive n , iff $q^{6nv(x)}w^{6nx} = 0$ for some positive n . We see by Lemma 2.10 that $q^{6nv(x)}w^{6nx} = 0$ iff $6nv(x) > v(6nx)$. Let $D \in \text{Del}(0)$ such that $x \in C(0, D) \cap X$. In the E_8 -case, $6x \in \text{Semi}(0, D)$ iff $x \in C(0, D) \cap X$ because $2x \in \text{Semi}(0, D_1)$ iff $x \in C(0, D_1) \cap X$, while $3x \in \text{Semi}(0, D_2)$ iff $x \in C(0, D_2) \cap X$. It follows that $6nv(x) > v(6nx)$ iff $6nv(x) > (6nx, \alpha(D))$. Thus $\bar{\xi}(x) = q^{v(x)}w^x \in \text{rad}(O_{0,Q_0})$ iff $v(x) > (x, \alpha(D))$. This proves the first part of the theorem. By Theorem 11.5 $v(x) = \lceil (x, \alpha(D)) \rceil$. Hence $v(x) > (x, \alpha(D))$ iff $(x, \alpha(D))$ is not an integer. This proves the second part of the theorem. Q.E.D.

Corollary 11.7. O_{c,Q_0} is nonreduced for any $c \in X$.

Corollary 11.8. *Let $f = \bar{\xi}(a)$ and $g = \bar{\xi}(b) \in O_{0,Q_0}$. Assume that $a, b \in C(0, D)$ for the same Delaunay cell $D \in \text{Del}(0)$. If $b \in \text{Semi}(0, D)$, then $fg \neq 0$ in O_{0,Q_0} .*

Proof. By Theorem 11.5, $v(a) = \lceil (a, \alpha(D)) \rceil$, while $v(b) = (b, \alpha(D))$ is an integer. Hence $v(a+b) = \lceil (a+b, \alpha(D)) \rceil = \lceil (a, \alpha(D)) \rceil + (b, \alpha(D)) = v(a) + v(b)$. It follows from Theorem 11.5 that $fg \neq 0$ in O_{c,Q_0} . Q.E.D.

Example 11.9. We give examples of nilpotent elements of O_{0,Q_0} . Let $D_1 = D(\frac{\omega_1}{2})$ and $D_2 = D(\frac{\omega_2}{3})$. Consider $\xi(h(\sigma_0))$. Then $h(\sigma_0) \in C(0, D_1) \cap X$, $(h(\sigma_0), \alpha(D_1)) = \frac{9}{2}$ and $v(h(\sigma_0)) = \lceil \frac{9}{2} \rceil = 5$. Consider next $\xi(h(\sigma_1))$. Then we see $h(\sigma_1) \in C(0, D_1) \cap X$, $(h(\sigma_1), \alpha(D_1)) = \frac{7}{2}$ and $v(h(\sigma_1)) = \lceil \frac{7}{2} \rceil = 4$. Finally consider $\xi(g_\infty)$. Then we see $g_\infty \in C(0, D_2) \cap X$, $(g_\infty, \alpha(D_2)) = \frac{8}{3}$ and $v(g_\infty) = \lceil \frac{8}{3} \rceil = 3$. It follows from these that

$$\xi(h(\sigma_0))^2 = \xi(h(\sigma_1))^2 = \xi(g_\infty)^3 = 0.$$

To be more precise, since

$$h(\sigma_0) = g_0 + 2h_0, \quad h(\sigma_1) = g_0 + h_0 + h_8, \quad g_\infty = g_0 + h_0,$$

$$\xi(h(\sigma_0)) = \xi_{g_0} \xi_{h_0}^2, \quad \xi(h(\sigma_1)) = \xi_{g_0} \xi_{h_0} \xi_{h_8}, \quad \xi(g_\infty) = \xi_{g_0} \xi_{h_0}.$$

we see

$$\xi(h(\sigma_0))^2 = q \cdot \xi_{h_0} \prod_{j=1}^7 \xi_{h_j}, \quad \xi(h(\sigma_1))^2 = q \cdot \xi_{h_8} \prod_{j=1}^6 \xi_{h_j},$$

$$\xi(g_\infty)^3 = q \cdot \xi_{g_0} \prod_{j=1}^7 \xi_{h_j}.$$

We note that $h(\sigma_0) \in C(0, D_1)$ and $h_0 \in D_1$, while $g_0 \notin D_1$ by Proposition 10.18 (i) because $(g_0, \omega_1) = 1 \neq 2$. Let $a_0 = \frac{1}{2}(3e_8 - e_6 + \sum_{k \neq 6,8} e_k)$. Then $a_0^2 = 4$, $(a_0, \omega_1) = 3$ and $(a_0, g_0) = 2$, which implies that $D(\frac{a_0}{2})$ is adjacent to $D_1 = D(\frac{\omega_1}{2})$ and $g_0 \in D(\frac{a_0}{2})$ by Proposition 10.15 (i) and Proposition 10.18 (i). In other words, though $g_0 \notin D_1$, g_0 belongs to $D(\frac{a_0}{2})$ adjacent to D_1 . We also note $g_0 \in D_2$, which is adjacent to D_1 .

Similarly $h(\sigma_1) \in C(0, D_1)$ and $h_0, h_8 \in D_1$, while $g_0 \notin D_1$ and $g_0 \in D(\frac{a_0}{2}) \cap D_2$ as we saw above. We see $h_0 \notin D_2$ because D_2 is a convex closure of $0, g_0$ and h_j ($1 \leq j \leq 7$), and $g_0^2 = h_j^2 = 2$, but $h_0^2 = 4$. Since $h_0 \in D_1$, h_0 belongs to a Delaunay cell D_1 adjacent to D_2 . See Proposition 10.15 (ii). Finally we note that $g_\infty \in C(0, D_2)$, $g_0 \in D_2$, while $h_0 \notin D_2$ but $h_0 \in D_1$, which is adjacent to D_2 .

Corollary 11.10. *The (reduced) support of $\xi(h(\sigma_k))$ (resp. $\xi(g_\infty)$) contains one of the irreducible components of $Q_0, V(D(\frac{\omega_1}{2})) \cap U(0)$ (resp. $V(D(\frac{\omega_2}{3})) \cap U(0)$).*

Proof. Let $Z = V(D(\frac{\omega_1}{2})) \cap U(0)$. Then Z is reduced by definition, whose coordinate ring $\Gamma(O_Z)$ is $k(0)[\text{Semi}(0, D(\frac{\omega_1}{2}))]$, the ring generated by the semi-group $\text{Semi}(0, D(\frac{\omega_1}{2}))$. No element of this ring except 0 annihilates $\xi(h(\sigma_k))$ in $R(0)$ by Theorem 11.5. Similarly the coordinate ring of $V(D(\frac{\omega_2}{3})) \cap U(0)$ is $k(0)[\text{Semi}(0, D(\frac{\omega_2}{3}))]$, none of whose elements except 0 annihilate $\xi(g_\infty)$. This proves the corollary. Q.E.D.

11.11. Degrees of irreducible components of Q_0

Let $D_1 = D(\frac{\omega_1}{2})$ or $D_2 = D(\frac{\omega_2}{3})$. Let $V(D_k)$ be the closure of \mathbf{G}_m^8 -orbit $O(D_k)$ with reduced structure. By Lemma 11.1 and Theorem 11.2, at a generic point of $V(\sigma)$, we have $\text{rank}_{k(V(D_1))} {}_n F_{D_1}^{0,0} = 2$ and

$\text{rank}_{k(V(D_2))} {}_n F_{D_1}^{0,0} = 3$. Thus by Proposition 10.5 and Proposition 10.11 we have an equivalence

$$Q_0 = 2 \cdot 135[X : Y]V(D_1) + 3 \cdot 1920[X : Y]V(D_2).$$

modulo identification of the irreducible components of Q_0 of the same type. By Theorem 5.15 we have

$$\begin{aligned} \dim \mathbf{H}^0({}_n F_{\sigma}^{0,\cdot}, \delta_n^{0,\cdot}) &= \# \left(\sigma \cap \frac{X}{n} \right) = \frac{\text{vol}(\sigma)}{8!} \cdot n^8 + O(n^7), \\ \dim \mathbf{H}^0({}_n F_{D_1}^{0,\cdot}, \delta_n^{0,\cdot}) &= \frac{2^7 \cdot 2}{8!} \cdot n^8 + O(n^7), \\ \dim \mathbf{H}^0({}_n F_{D_2}^{0,\cdot}, \delta_n^{0,\cdot}) &= \frac{3}{8!} \cdot n^8 + O(n^7). \end{aligned}$$

Since $\mathbf{H}^q({}_n F_{\sigma}^{k,\cdot}, \delta_n^{k,\cdot}) = 0$ ($q > 0$), we have $2 \cdot (L_{V(D_1)}^8) = \text{vol}(D_1) = 2^8$, and $3 \cdot (L_{V(D_2)}^8) = \text{vol}(D_2) = 3$. Thus we have

$$\begin{aligned} L_{Q_0}^8 &= (L^8 Q_0)_{(Q, \partial Q)} \\ &= L^8 (2 \cdot 135[X : Y]V(D_1) + 3 \cdot 1920[X : Y]V(D_2))_{(Q, \partial Q)} \\ &= [X : Y] \left(135 \cdot 2 \cdot (L_{V(D_1)}^8) + 1920 \cdot 3 \cdot (L_{V(D_2)}^8) \right) \\ &= [X : Y](135 \cdot 2^8 + 1920 \cdot 3) = 8! \cdot [X : Y] \end{aligned}$$

which is compatible with $L_{Q_0}^8 = L_{Q_n}^8 = 8! \cdot [X : Y]$.

References

- [A02] V. Alexeev, *Complete moduli of abelian varieties in the presence of semi-abelian group action*, Ann. of Math. **155** (2002) 611-708.
- [AN99] V. Alexeev and I. Nakamura, *On Mumford's construction of degenerating abelian varieties*, Tôhoku Math. J. **51** (1999) 399-420
- [Bourbaki] Bourbaki, *Groupes et algebres de Lie*, Chap. 4, 5 et 6 (1981).
- [MP92] R. V. Moody and J. Patera, *Voronoi and Delaunay cells of root lattices: classification of their faces and faces by Coxeter-Dynkin diagrams*, J. Physics A: Math. **25** (1992) 5089-5134.
- [M72] D. Mumford, *An analytic construction of degenerating abelian varieties over complete rings*, Compositio Math. **24** (1972) 239-272.
- [M74] D. Mumford, *Abelian Varieties*, Tata Institute of Fundamental Research, Bombay and Oxford University Press, (1974).
- [Nr75] I. Nakamura, *On moduli of stable quasi abelian varieties*, Nagoya Math. J. **58** (1975), 149-214.

- [Nr99] I. Nakamura, *Stability of degenerate abelian varieties*, Invent. Math. **136** (1999), 659–715.
- [Nw76] Y. Namikawa, *A new compactification of the Siegel space and degenerations of abelian varieties*, I, II, Math. Ann. **221** (1976), 97–141, 201–241.
- [V09] G. Voronoi, *Nouvelles applications des paramètres continus à la théorie des formes quadratiques*, I,II,III, J. Reine Angew. Math. **133** (1908) 97–178, **134** (1908) 198–287, **136** (1909) 67–181.

Iku Nakamura
Department of Mathematics
Hokkaido University
Sapporo, 060-0810
Japan

Ken Sugawara
Department of Mathematics
Hokkaido University of Education at Sapporo
Sapporo, 002-8502
Japan